



GAI-TRONICS® CORPORATION
A HUBBELL COMPANY

Model 69037-101

Station Card for Centra-Page Systems

Confidentiality Notice

This manual is provided solely as an operational, installation, and maintenance guide and contains sensitive business and technical information that is confidential and proprietary to GAI-Tronics. GAI-Tronics retains all intellectual property and other rights in or to the information contained herein, and such information may only be used in connection with the operation of your GAI-Tronics product or system. This manual may not be disclosed in any form, in whole or in part, directly or indirectly, to any third party.

Introduction

GAI-Tronics Centra-Page system provides dependable paging and party line communications for rugged and hazardous industrial facilities. Centra-Page features centrally-located electronics that provide environmental protection and unitized amplification for easy maintenance. Standard Model 10468-002 Centra-Page cabinets can support up to 30 handset stations and in most cases up to 60 paging speakers. Alarms and telephone interfacing can also be added to Centra-Page systems.

The heart of the system is a centrally-located card rack containing printed circuit board assemblies (PCBAs) Model 69037-101. One plug-in PCBA, also referred to as a line card, is placed in the central card rack assembly for each independent station and speaker. Each line card contains a handset dc power source, dual-switching relays and a 16-watt speaker amplifier with 8-ohm and 70.7 V line outputs. Additionally, each card has a paging-level speaker volume control (which does **not** affect alarm signal level), and a removable link to silence the speaker amplifier for page calls from that station, preventing acoustic feedback. Each card also contains five LED indicators for operating condition or mode.

The Model 69037-101 Station Line Card plugs into a Model 10461-002 Centra-Page Card Rack located in the central cabinet. The central cabinet is installed in a non-hazardous area. The Model 69037-101 contains both the handset amplifier power supply and an amplifier for an associated speaker or horn/driver combination.

As shown in Figure 2, the LEDs located along the edge of the card allow a technician to easily perform troubleshooting at the central cabinet. Each line card contains a 16-watt audio amplifier fed from the page line bus that is intended to drive loudspeakers in the vicinity of the handset station. There is a volume control and mute link on the input to each amplifier. The control and link are actually located on the 10461-002 Card Rack so adjustments for various locations are maintained even though line cards are replaced or exchanged.

The function of the muting is to silence the loudspeakers in the vicinity of a handset station when page calls are initiated from that station. This prevents acoustic feedback which may be a problem depending on loudspeaker location. The equipment is not configured for this option when shipped from the factory. If the muting feature is desired, please refer to the 10461-002 Card Rack manual for instructions on how to enable this option.

Installation

1. Open the Centra-Page cabinet to access the front panel.
2. Slide the 69037-101 card into the grooves associated with the proper station. Make sure that the connector at the rear of the card has plugged firmly into the connector in the card rack. All the components should face to the right. The card is keyed so that it cannot be plugged in backwards.
3. Snap the white clip on the front of the card into place to secure the card in the card rack.
4. Open the Centra-Page cabinet to access the rear of the card rack.
5. Refer to Figure 1. Complete the connections to the terminal blocks as noted.
6. Make the connections to the speakers using 14, 16, or 18AWG cable. The gauge of wire needed is determined by the distance between the central cabinet and the speakers. The larger the wire gauge, the greater the distance that can be covered
7. Adjust the speaker level using a small standard screwdriver inserted into the hole labeled **SPKR. LEVEL**.

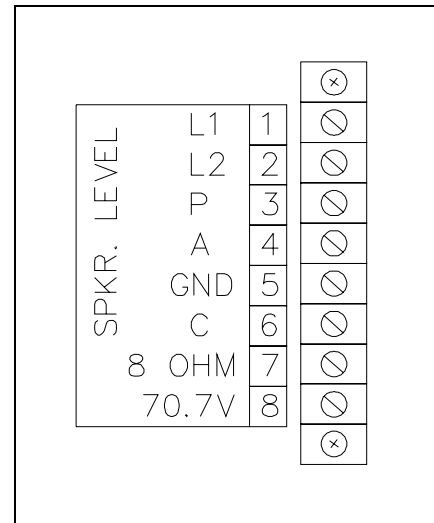

Figure 1. Wiring to Card Rack

Card Status LED Indicators

The following tables illustrate how to determine the status of the station card based on the combination of the LED indicators that are lit.

Speaker Amplifier Status

CR23 (red) is the “in use” indicator, and CR24 (green) is the speaker amplifier power indicator.

Speaker Amplifier Status	CR23 (Red)	CR24 (Green)
Speaker Amplifier Power Off	Off*	Off
Speaker Amplifier Fuse (F1) is Open	Off*	Off
Speaker Amplifier On – No audio	Off	On
Speaker Amplifier On – Audio Signal Present	Modulated by audio signal	On
With no audio present – Speaker Amplifier Failure	On	On

*CR24 is a power indicator for the speaker amplifier. When CR24 is off, CR23 must be off.

Handset Status

CR13 (red) and CR15 (yellow) are the handset status indicators, and CR16 (green) is the handset power indicator.

Handset Status	CR13 (Red)	CR15 (Yellow)	CR16 (Green)
On-hook	Off	Off	On
Off-hook (paging)	On	On	On
Off-hook (Party 1)	Off	On	On
Off-hook (Party 2)	On	Off	On
L1/L2 shorted	Off	Off	Off

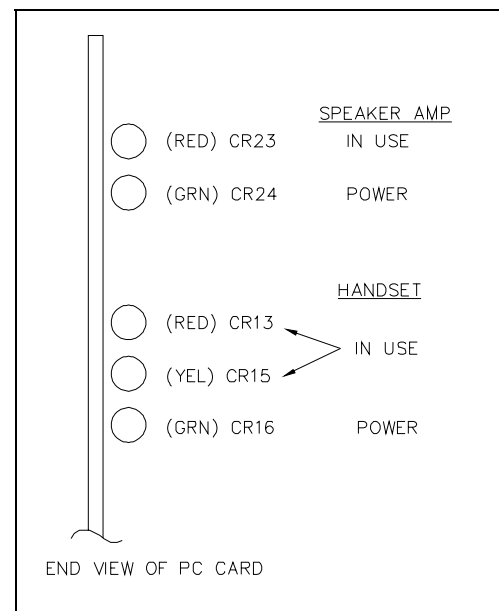

Figure 2. LED Details

Speakers

8-Ohm Out Operation

When using the 8-ohm output connections, always use speakers of proper voice coil impedance and power handling capability. Consult GAI-Tronics Pub. 42004-135 and 42004-220 for more details on speaker installation and wiring.

70.7 Volt Out Operation

Greater speaker line distances from the central cabinet can be obtained by using the 70.7 V output connection compared with using 8-ohm output. The individual speaker's power level is determined by the tap settings on the line-matching transformer. The use of these transformers allows the speakers to be placed at longer distances from the central amplifier system without significant power loss.

The sum of the speaker power settings must not exceed the total power available from the amplifier PCBA. For example, the 69037-101 PCBA's 70.7 V output (~16 W out with ~27 V dc in) can drive approximately eight speakers tapped at 2 watts each or four speakers tapped at 4 watts each.

Speaker Wiring Distance Guide

Cable distance should be kept as short as possible to reduce the power loss. The following chart illustrates the correlation between three typical wire sizes and the distance that speakers with integral drivers or horns with separate drivers can be placed from the central card rack for a -1 dB loss (-20% power loss). For a 0.5 dB loss, divide all lengths in half.

Table 1.

Speaker Wiring Guidelines for 69037-101 PCBA Based on ~27 V DC Input to Card Rack Assembly			
Speaker Output Connection	Wire Size		
	18 AWG (0.82 mm ²)	16 AWG (1.31 mm ²)	14 AWG (2.08 mm ²)
8-Ohm Out	77 feet (23.5 meters)	123 feet (37.5 meters)	196 feet (59.7 meters)
70.7 Volt Out	2,900 feet (884 meters)	4,700 feet (1,432 meters)	7,500 feet (2,286 meters)

Warranty

Equipment. GAI-Tronics warrants for a period of one (1) year from the date of shipment, that any GAI-Tronics equipment supplied hereunder shall be free of defects in material and workmanship, shall comply with the then-current product specifications and product literature, and if applicable, shall be fit for the purpose specified in the agreed-upon quotation or proposal document. If (a) Seller's goods prove to be defective in workmanship and/or material under normal and proper usage, or unfit for the purpose specified and agreed upon, and (b) Buyer's claim is made within the warranty period set forth above, Buyer may return such goods to GAI-Tronics' nearest depot repair facility, freight prepaid, at which time they will be repaired or replaced, at Seller's option, without charge to Buyer. Repair or replacement shall be Buyer's sole and exclusive remedy. The warranty period on any repaired or replacement equipment shall be the greater of the ninety (90) day repair warranty or one (1) year from the date the original equipment was shipped. In no event shall GAI-Tronics warranty obligations with respect to equipment exceed 100% of the total cost of the equipment supplied hereunder. Buyer may also be entitled to the manufacturer's warranty on any third-party goods supplied by GAI-Tronics hereunder. The applicability of any such third-party warranty will be determined by GAI-Tronics.

Services. Any services GAI-Tronics provides hereunder, whether directly or through subcontractors, shall be performed in accordance with the standard of care with which such services are normally provided in the industry. If the services fail to meet the applicable industry standard, GAI-Tronics will re-perform such services at no cost to buyer to correct said deficiency to Company's satisfaction provided any and all issues are identified prior to the demobilization of the Contractor's personnel from the work site. Re-performance of services shall be Buyer's sole and exclusive remedy, and in no event shall GAI-Tronics warranty obligations with respect to services exceed 100% of the total cost of the services provided hereunder.

Warranty Periods. Every claim by Buyer alleging a defect in the goods and/or services provided hereunder shall be deemed waived unless such claim is made in writing within the applicable warranty periods as set forth above. Provided, however, that if the defect complained of is latent and not discoverable within the above warranty periods, every claim arising on account of such latent defect shall be deemed waived unless it is made in writing within a reasonable time after such latent defect is or should have been discovered by Buyer.

Limitations / Exclusions. The warranties herein shall not apply to, and GAI-Tronics shall not be responsible for, any damage to the goods or failure of the services supplied hereunder, to the extent caused by Buyer's neglect, failure to follow operational and maintenance procedures provided with the equipment, or the use of technicians not specifically authorized by GAI-Tronics to maintain or service the equipment. **THE WARRANTIES AND REMEDIES CONTAINED HEREIN ARE IN LIEU OF AND EXCLUDE ALL OTHER WARRANTIES AND REMEDIES, WHETHER EXPRESS OR IMPLIED BY OPERATION OF LAW OR OTHERWISE, INCLUDING ANY WARRANTIES OF MERCHANTABILITY OR FITNESS FOR A PARTICULAR PURPOSE.**

Return Policy

If the equipment requires service, contact your Regional Service Center for a return authorization number (RA#). Equipment should be shipped prepaid to GAI-Tronics with a return authorization number and a purchase order number. If the equipment is under warranty, repairs or a replacement will be made in accordance with the warranty policy set forth above. Please include a written explanation of all defects to assist our technicians in their troubleshooting efforts.

Call 800-492-1212 (inside the USA) or 610-777-1374 (outside the USA) for help identifying the Regional Service Center closest to you.