



GAI-TRONICS® CORPORATION
A HUBBELL COMPANY

Model 10461-002 Centra-Page Card Rack

Confidentiality Notice

This manual is provided solely as an operational, installation, and maintenance guide and contains sensitive business and technical information that is confidential and proprietary to GAI-Tronics. GAI-Tronics retains all intellectual property and other rights in or to the information contained herein, and such information may only be used in connection with the operation of your GAI-Tronics product or system. This manual may not be disclosed in any form, in whole or in part, directly or indirectly, to any third party.

Introduction

The GAI-Tronics Centra-Page system provides dependable paging and party line communications for rugged and hazardous industrial facilities. Centra-Page features centrally located electronics that provide environmental protection for components. Standard Centra-Page cabinets can support up to 30 handset stations. Alarms and telephone interfacing can also be added to Centra-Page systems.

General Information

The Model Centra-Page 10461-002 Card Rack is one of the primary components of a Centra-Page system. All Centra-Page systems require at least one card rack, which houses the individual line cards that correspond to specific handset stations and speakers in the system. The card rack contains termination points for 22 to 28.8 V dc power as well as the alarm/tone generator and the telephone interface connections.

Each card rack has the capacity for holding up to ten GAI-Tronics Model 69037-101 Line Cards. These cards plug easily into the rack with the card ejectors at the top and components to the right. The cards are keyed so that they cannot be plugged in backwards. Centra-Page systems using the Model 10468-002 Centra-Page Central Cabinet have maximum capacity of three card racks and therefore 30 line cards (and stations). Some large Centra-Page systems involve custom cabinets or other customer-designed installations.

All of the handset stations and speakers in a Centra-Page system are homerun (individually) wired back to the card rack(s). Terminations for each station and associated speaker are found in the rear of the card rack. For wiring information, refer to Figure 1, which illustrates a typical Centra-Page system, to the Model 10468-002 Centra-Page Central Cabinet manual, Pub. 42004-222, and the individual component manuals.

When a Model 10961-001 AMI Centra-Page Interface is used in a Centra-Page system, priority encoded tones are sent over all speakers in the system through the line cards. Refer to Pub. 42004-345 and 42004-371 for details of operation. Additionally, a telephone line can be connected to the system allowing off-site personnel to communicate to those in the plant or facility.

Hazardous Areas

The Model 10461 Card Rack must be mounted in a non-hazardous area, although other portions of the Centra-Page system may be located in Div. I or Div. II hazardous areas if appropriate wiring configurations and barriers are used. Refer to Pub. 42004-356, Control Drawing 72979, for proper installation of stations for intrinsically safe operation in Class I, Div. I, Group C and D hazardous areas.

A typical Centra-Page system with components in both hazardous and non-hazardous areas is shown in Figure 1.

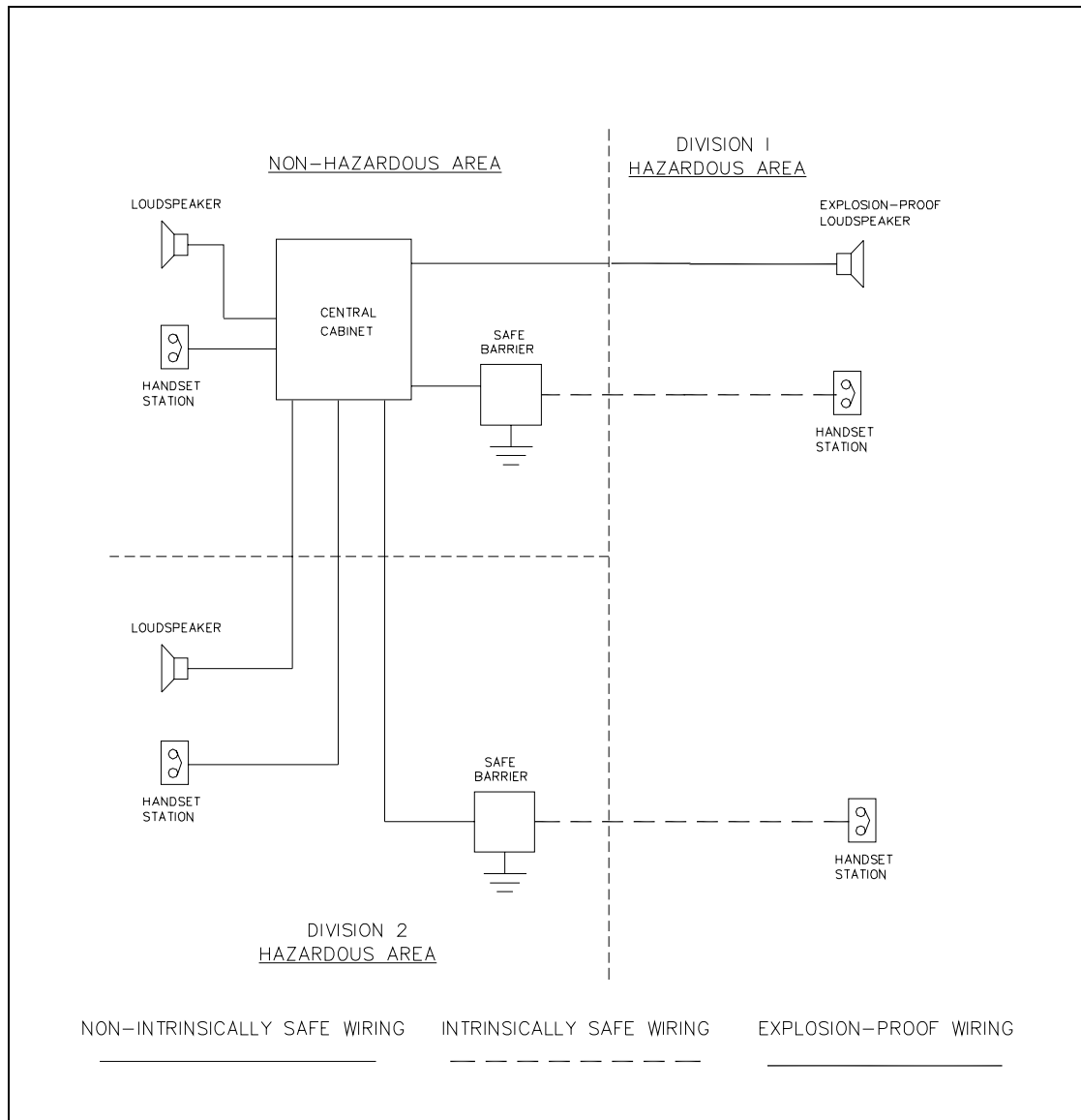

Figure 1. Typical Centra-Page System Diagram

Installation

Power Requirements

This equipment is designed for nominal 24 V dc operation (22 to 28.8 V) with the negative side grounded, 20 amps maximum, 2 amps idle. However, neither power supply lead is actually wired to the ground terminal.

The Centra-Page system may be used with negative ground, positive ground, or ungrounded power sources. The card rack must be mounted in a non-hazardous area.

If installing a station and line card as an add-on, please consult the following chart to ensure proper power will be supplied.

Power Supply Current Requirements

Mode	10 Cards	20 Cards	30 Cards
Standby	0.8 amp	1.5 amps	2.3 amps
Page (maximum load)	5.7 amps	11.4 amps	17.1 amps
Alarm (typical)	3.8 amps	7.5 amps	11.3 amps
Alarm (maximum level)	12.5 amps	25.0 amps	37.5 amps

Notes regarding power supply current requirements listed above:

1. Ratings at 27.0 V dc at the central cabinet. Add 8% for page and alarm at 28.8 V dc.
2. Full load is defined as 15-watt load on all cards with levels adjusted at factory; 2-watt alarm output.
3. Typical load is defined as 7.5-watt load (such as 16-ohm loudspeaker connected to 8-ohm output).
4. Maximum level is defined as 15-watt loads and level control adjusted for 15-watt alarm level on all cards.
5. Ratings for alarm based on continuous tones. Pulse tone reduces current to about 60%.

Model 10461-002 Centra-Page Card Rack

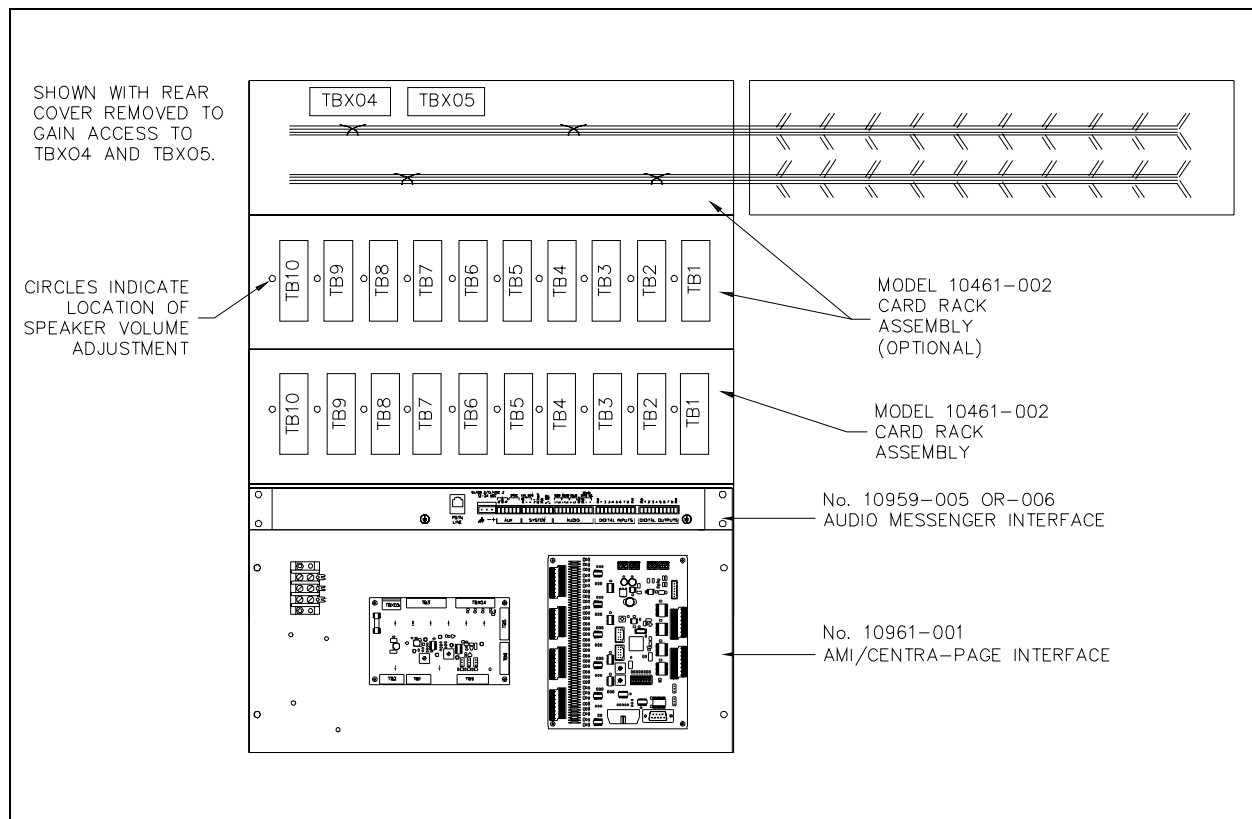

Figure 2. General Outline Details

Installation Procedure

1. Carefully unpack and identify the components. A parts envelope containing the mounting screws and 11 jumper wires is included.
2. Refer to Figure 2. The Model 10461-002 Card Rack(s) is mounted in a Model 10468-002 Centra-Page Central Cabinet, or similar 19-inch cabinet. If mounting more than one card rack or a Model 10961-001 AMI Centra-Page Interface, all components should be kept together. There should be no blank panel space between these pieces of equipment or the interconnecting jumpers will not be long enough.
3. For easy access to TBX04 and TBX05, remove the four screws that hold the back panel on the card rack. This is the panel with TB1 through TB10 mounted on it. Refer to Figure 2 for details.
4. Carefully swing the panel to the right as if the right side (as viewed from the rear) were hinged. Do not put excessive strain on the wiring harnesses. TBX04 and TBX05 are now exposed.
5. Connect 22 to 28.8 V dc power to TBX05. If more than one card rack is being used, connect the TBX05 terminal blocks with the three thick jumpers provided.
6. Connect signal and control conductors to TBX04. Be sure the wiring scheme is consistent from one rack to the next rack.
7. When reassembling after the jumpers are in place, be certain all harnesses are returned to their previous locations. Mount the panel to the rear, stationary portion of the Model 10468-002 Central Cabinet.

8. Wiring from the terminal blocks (TB1 through TB10) on the rear of the card rack to the associated handset station and speaker can be accomplished in several ways. See Figure 1. In each wiring option, terminal connections L1, L2, P, and A on the card rack correspond to L1, L2, P, and A on the terminal strips on each handset station. The remaining two conductors are connected to C and either 70.7 V or 8 ohm for loudspeaker wiring. See the Cabling section below for additional information.
9. Plug the Model 69037-101 Line Cards into the card rack with the card ejectors at the top, and the components on the right.
10. Adjust the speaker level using a small standard screwdriver inserted into the hole labeled SPKR. LEVEL.

If you are assembling the Centra-Page system in the field, refer to the specific instruction manuals for individual components. These manuals explain in detail how to install and connect the various components of a Centra-Page system to the Model 10468-002 Central Cabinet. The manuals for these components are listed below:

Pub. Number	Component/Title
42004-214	Model 473-002 Centra-Page Outdoor Wall Station
42004-215	Model 472-002 Centra-Page Permanent Indoor 2-Party Station
42004-216	Model 476-002 Centra-Page Flush Mount Station
42004-220	Model 10461-002 Centra-Page Card Rack
42004-221	Model 69037-101 Centra-Page Station Card
42004-227	Model C83018 Centra-Page Station Crew's Quarters Mute Card
42004-371	Model 10961-001 AMI Centra-Page Interface
42004-345	Model 10959-006 Rack-Mount Audio Messenger Interface

Cabling Requirements

GAI-Tronics recommends the use of three 18 AWG twisted pairs, with each pair of conductors individually shielded (GAI-Tronics Model 60051 Series cable). However, as longer cable distances are required, larger wire sizes may be appropriate. The table below lists distance limitations for 1 dB loss for paging/speaker output.

Wire Size	8-Ohm Output	70.7 V Output
18 AWG	75 feet (25 m)	6250 feet (1900 m)
16 AWG	120 feet (35 m)	9900 feet (3000 m)
14 AWG	200 feet (60 m)	15,800 feet (4800 m)

Wiring Drivers/Loudspeakers to Centra-Page System

When using the common and 70.7 V output from the Centra-Page card rack, the driver unit for the loudspeaker must contain a 70.7 V line-matching transformer. GAI-Tronics offers the following driver products that can be used in this situation.

Hazardous Areas	
Div. 2:	Model 13314-002 Model 13314-003 (70.7 volt transformer)
Div. 1:	Model 13310-201 Model 13310-203 (70.7 volt transformer)

When wiring the Model 13314-003 with 70.7 V transformer driver:

- Connect the incoming common conductor to the black common conductor on the primary side of the transformer.
- Connect the incoming 70.7 V conductor to the red, 15-watt conductor for maximum output.
- To reduce the sound pressure level by 3 dB, connect the incoming 70.7 V conductor to the orange 7.5 watt tap.
- To reduce the SPL by another 3 dB, use the yellow 3.7-watt tap.

Please see Figure 3 for further wiring details.

When wiring the Model 13310-203 Driver:

- Connect the incoming common conductor to the white common on the primary side of the transformer.
- Connect the incoming 70.7 V conductor to the black conductor.
- On the secondary side, connect the gray common conductor to the white conductor on the remaining half of the driver, and the desired watt conductor to the remaining black conductor. See the table below:

Wattage	Color
30	Purple
15	Blue
10	Green
5	Orange
2.5	Brown
1.5	Yellow

When using the GAI-Tronics Model 13351 Integral Speaker, connect the incoming conductors to the labeled terminal block inside the unit according to the desired wattage tap.

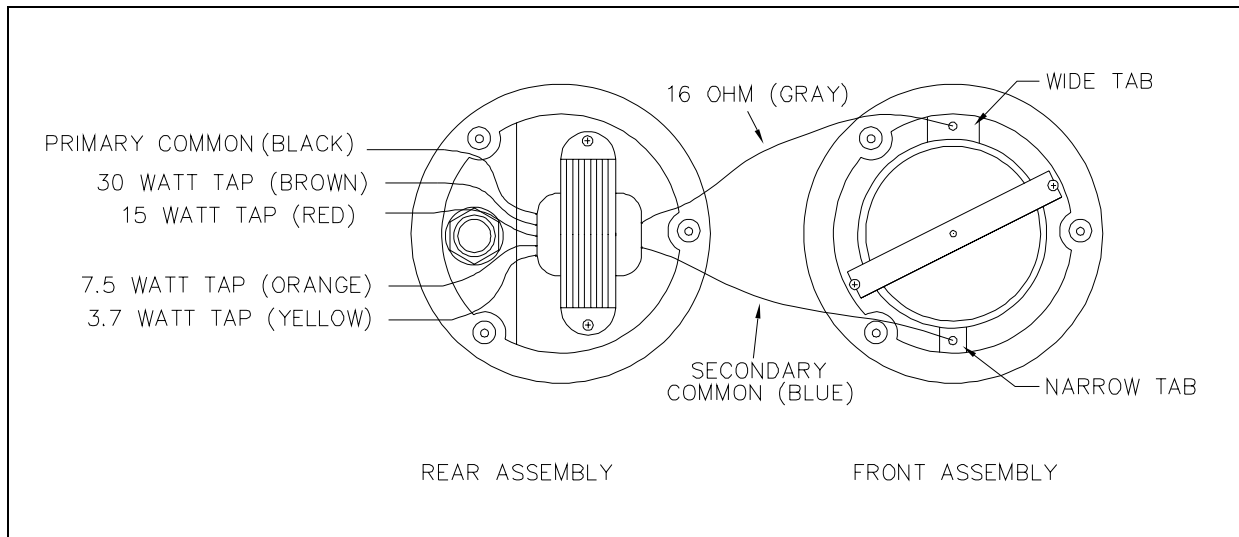

Figure 3. Wiring Details for Model 13314-003

Speaker Muting

The Model 10461-002 Card Rack and Model 69037-101 Line Cards are factory-set so that all associated speakers broadcast pages made on the system. However, if a speaker is located too close to a handset, acoustic coupling may occur during a page from that handset and cause feedback over the entire system.

To eliminate this problem, the speaker can be muted by cutting the blue wire that loops from pin 2 to pin 10 on the connector that the station card plugs into. These blue jumpers are found on each connector in the rack.

NOTE: This muting procedure affects handset pages only, and does not affect alarm signals.

This procedure is permanent once completed. If temporary muting is required, contact your GAI-Tronics Service Center for additional information.

Operation

The card rack itself has no user operation functions. Refer to the individual component manuals for specific operational instructions.

Warranty

Equipment. GAI-Tronics warrants for a period of one (1) year from the date of shipment, that any GAI-Tronics equipment supplied hereunder shall be free of defects in material and workmanship, shall comply with the then-current product specifications and product literature, and if applicable, shall be fit for the purpose specified in the agreed-upon quotation or proposal document. If (a) Seller's goods prove to be defective in workmanship and/or material under normal and proper usage, or unfit for the purpose specified and agreed upon, and (b) Buyer's claim is made within the warranty period set forth above, Buyer may return such goods to GAI-Tronics' nearest depot repair facility, freight prepaid, at which time they will be repaired or replaced, at Seller's option, without charge to Buyer. Repair or replacement shall be Buyer's sole and exclusive remedy. The warranty period on any repaired or replacement equipment shall be the greater of the ninety (90) day repair warranty or one (1) year from the date the original equipment was shipped. In no event shall GAI-Tronics warranty obligations with respect to equipment exceed 100% of the total cost of the equipment supplied hereunder. Buyer may also be entitled to the manufacturer's warranty on any third-party goods supplied by GAI-Tronics hereunder. The applicability of any such third-party warranty will be determined by GAI-Tronics.

Services. Any services GAI-Tronics provides hereunder, whether directly or through subcontractors, shall be performed in accordance with the standard of care with which such services are normally provided in the industry. If the services fail to meet the applicable industry standard, GAI-Tronics will re-perform such services at no cost to buyer to correct said deficiency to Company's satisfaction provided any and all issues are identified prior to the demobilization of the Contractor's personnel from the work site. Re-performance of services shall be Buyer's sole and exclusive remedy, and in no event shall GAI-Tronics warranty obligations with respect to services exceed 100% of the total cost of the services provided hereunder.

Warranty Periods. Every claim by Buyer alleging a defect in the goods and/or services provided hereunder shall be deemed waived unless such claim is made in writing within the applicable warranty periods as set forth above. Provided, however, that if the defect complained of is latent and not discoverable within the above warranty periods, every claim arising on account of such latent defect shall be deemed waived unless it is made in writing within a reasonable time after such latent defect is or should have been discovered by Buyer.

Limitations / Exclusions. The warranties herein shall not apply to, and GAI-Tronics shall not be responsible for, any damage to the goods or failure of the services supplied hereunder, to the extent caused by Buyer's neglect, failure to follow operational and maintenance procedures provided with the equipment, or the use of technicians not specifically authorized by GAI-Tronics to maintain or service the equipment. **THE WARRANTIES AND REMEDIES CONTAINED HEREIN ARE IN LIEU OF AND EXCLUDE ALL OTHER WARRANTIES AND REMEDIES, WHETHER EXPRESS OR IMPLIED BY OPERATION OF LAW OR OTHERWISE, INCLUDING ANY WARRANTIES OF MERCHANTABILITY OR FITNESS FOR A PARTICULAR PURPOSE.**

Return Policy

If the equipment requires service, contact your Regional Service Center for a return authorization number (RA#). Equipment should be shipped prepaid to GAI-Tronics with a return authorization number and a purchase order number. If the equipment is under warranty, repairs or a replacement will be made in accordance with the warranty policy set forth above. Please include a written explanation of all defects to assist our technicians in their troubleshooting efforts.

Call 800-492-1212 (inside the USA) or 610-777-1374 (outside the USA) for help identifying the Regional Service Center closest to you.