



GAI-TRONICS® CORPORATION
A HUBBELL COMPANY

Model 230-001 Pole Mounting Kit

Confidentiality Notice

This manual is provided solely as an operational, installation, and maintenance guide and contains sensitive business and technical information that is confidential and proprietary to GAI-Tronics. GAI-Tronics retains all intellectual property and other rights in or to the information contained herein, and such information may only be used in connection with the operation of your GAI-Tronics product or system. This manual may not be disclosed in any form, in whole or in part, directly or indirectly, to any third party.

General Information

The Model 230-001 Pole Mounting Kit is for use with all GAI-Tronics LEXAN® and polyester weatherproof enclosures. Instructions for mounting the bracket to a pole are listed below. After the bracket is mounted, refer to the installation instructions for your type of enclosure: either LEXAN® or polyester.

Bracket Mounting Procedure

1. The bracket should be mounted 54 inches from the floor to the centerline of the bracket.
2. For poles up to 5 inches in diameter, the 1/2-13 × 1-1/2 inch hex head machine screws should be used. The pole should be drilled and tapped for 1/2-13 bolts. See Figure 1.
3. For poles over 5 inches in diameter, and up to 15 inches in diameter, universal clamps should be used. See Figure 1.

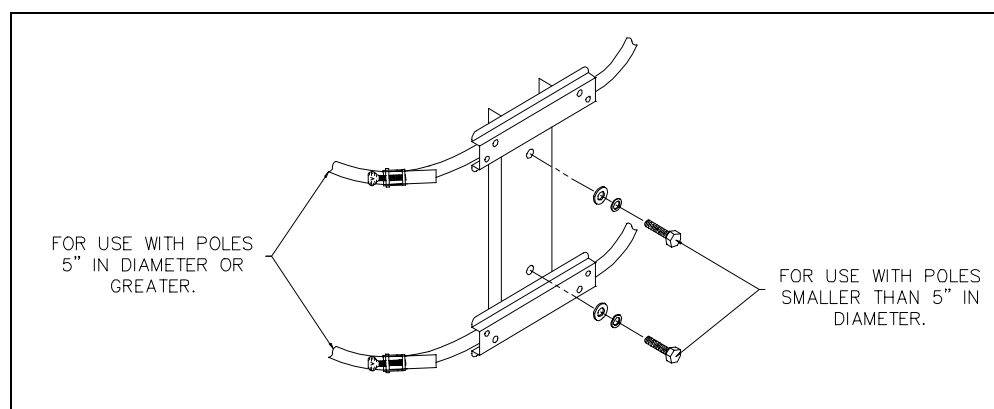
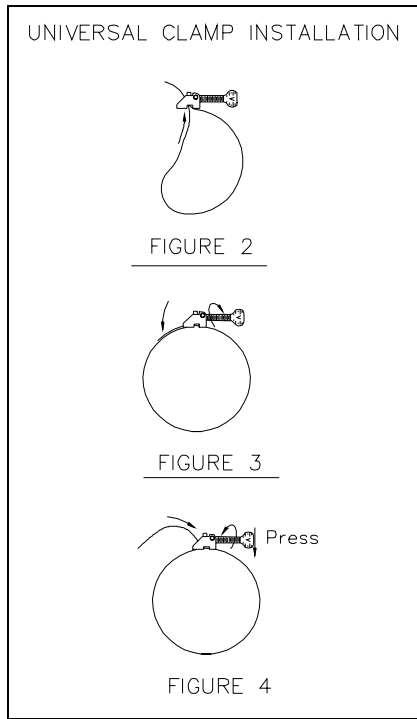

Figure 1. Bracket Mounting Diagram

To Install: With the screw fully retracted, wrap the band around the pole. Insert the free end of the band through the bottom slot in the bracket. See Figure 2.

To Tighten: Pull the band tight around the pole, and maintain the tension while pulling the band back away from the screw. Tighten the thumbscrew. For extra clamping pressure, use pliers or a wrench. See Figure 3.

To Remove: Loosen the thumbscrew to the fully retracted position. Press down on the thumbscrew, and feed the loose end of the strap back through the slot. See Figure 4.



Lexan® Enclosure Mounting

Use the hex head 5/16-18 × 1-inch machine screws, lock washers, and flat washers, to bolt the enclosure onto the bracket as shown in Figure 5.

Polyester Enclosure Mounting

1. Open the door to gain access to the equipment.
2. Loosen the four outer screws, pull back the mid-section, disconnect any cables, and pull the unit away from the rear enclosure.
3. Mount the rear enclosure to the bracket using the Phillips head ¼-20 × 1-inch machine screws and lock washers. See Figure 6.
4. Replace the mid-section by reconnecting the cables, pushing the mid-section into place, and tightening the four outer screws.

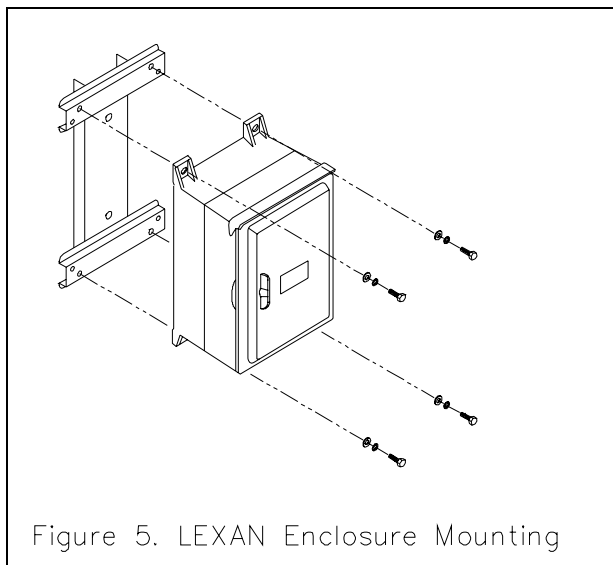

Figure 5. LEXAN Enclosure Mounting

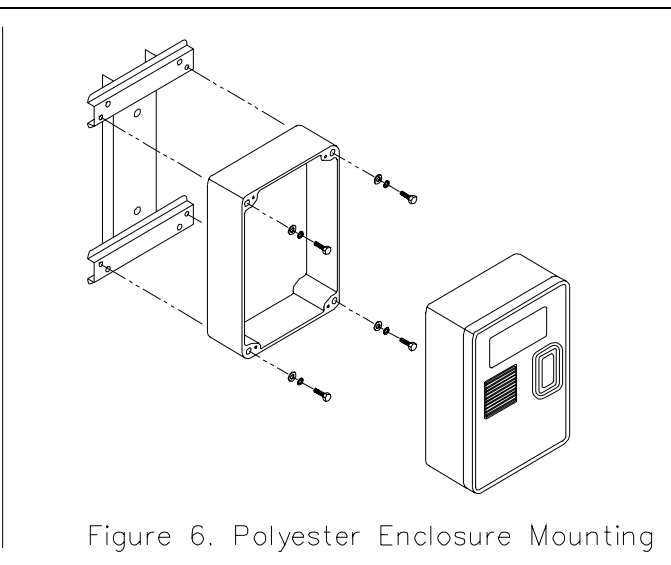

Figure 6. Polyester Enclosure Mounting

Warranty

Equipment. GAI-Tronics warrants for a period of one (1) year from the date of shipment, that any GAI-Tronics equipment supplied hereunder shall be free of defects in material and workmanship, shall comply with the then-current product specifications and product literature, and if applicable, shall be fit for the purpose specified in the agreed-upon quotation or proposal document. If (a) Seller's goods prove to be defective in workmanship and/or material under normal and proper usage, or unfit for the purpose specified and agreed upon, and (b) Buyer's claim is made within the warranty period set forth above, Buyer may return such goods to GAI-Tronics' nearest depot repair facility, freight prepaid, at which time they will be repaired or replaced, at Seller's option, without charge to Buyer. Repair or replacement shall be Buyer's sole and exclusive remedy. The warranty period on any repaired or replacement equipment shall be the greater of the ninety (90) day repair warranty or one (1) year from the date the original equipment was shipped. In no event shall GAI-Tronics warranty obligations with respect to equipment exceed 100% of the total cost of the equipment supplied hereunder. Buyer may also be entitled to the manufacturer's warranty on any third-party goods supplied by GAI-Tronics hereunder. The applicability of any such third-party warranty will be determined by GAI-Tronics.

Services. Any services GAI-Tronics provides hereunder, whether directly or through subcontractors, shall be performed in accordance with the standard of care with which such services are normally provided in the industry. If the services fail to meet the applicable industry standard, GAI-Tronics will re-perform such services at no cost to buyer to correct said deficiency to Company's satisfaction provided any and all issues are identified prior to the demobilization of the Contractor's personnel from the work site. Re-performance of services shall be Buyer's sole and exclusive remedy, and in no event shall GAI-Tronics warranty obligations with respect to services exceed 100% of the total cost of the services provided hereunder.

Warranty Periods. Every claim by Buyer alleging a defect in the goods and/or services provided hereunder shall be deemed waived unless such claim is made in writing within the applicable warranty periods as set forth above. Provided, however, that if the defect complained of is latent and not discoverable within the above warranty periods, every claim arising on account of such latent defect shall be deemed waived unless it is made in writing within a reasonable time after such latent defect is or should have been discovered by Buyer.

Limitations / Exclusions. The warranties herein shall not apply to, and GAI-Tronics shall not be responsible for, any damage to the goods or failure of the services supplied hereunder, to the extent caused by Buyer's neglect, failure to follow operational and maintenance procedures provided with the equipment, or the use of technicians not specifically authorized by GAI-Tronics to maintain or service the equipment. **THE WARRANTIES AND REMEDIES CONTAINED HEREIN ARE IN LIEU OF AND EXCLUDE ALL OTHER WARRANTIES AND REMEDIES, WHETHER EXPRESS OR IMPLIED BY OPERATION OF LAW OR OTHERWISE, INCLUDING ANY WARRANTIES OF MERCHANTABILITY OR FITNESS FOR A PARTICULAR PURPOSE.**

Return Policy

If the equipment requires service, contact your Regional Service Center for a return authorization number (RA#). Equipment should be shipped prepaid to GAI-Tronics with a return authorization number and a purchase order number. If the equipment is under warranty, repairs or a replacement will be made in accordance with the warranty policy set forth above. Please include a written explanation of all defects to assist our technicians in their troubleshooting efforts.

Call 800-492-1212 (inside the USA) or 610-777-1374 (outside the USA) for help identifying the Regional Service Center closest to you.