



GAI-TRONICS® CORPORATION
A HUBBELL COMPANY

Electro-Sound Communications System

Confidentiality Notice

This manual is provided solely as an operational, installation, and maintenance guide and contains sensitive business and technical information that is confidential and proprietary to GAI-Tronics. GAI-Tronics retains all intellectual property and other rights in or to the information contained herein, and such information may only be used in connection with the operation of your GAI-Tronics product or system. This manual may not be disclosed in any form, in whole or in part, directly or indirectly, to any third party.

Introduction

The GAI-Tronics Electro-Sound Communications System is a hands-free headset and/or telephone-type handset system that can be used for start-up, maintenance, adjustments, operations, temporary communications, and a common-talking system over large areas at minimum cost. Electro-Sound is not only useful during plant shutdown, but can be used in areas of extreme noise when the plant is in full operation. Electro-Sound satisfactorily replaces sound-powered telephones with an amplified system.

Notice: Effective Jan. 1, 2005 the Electro-Sound Communications System and its components will not maintain any Nationally Recognized Laboratory Approvals for hazardous area locations.

Features

- Operates in high-noise areas
- Noise-canceling dynamic transmitters and anti-sidetone circuitry
- Up to 15 headsets or handsets in use at one time
- Interface capabilities to monitor speakers, paging system, alarms, and Page/Party® system
- Two-mile (maximum) capabilities from power source to handset station

A standard system includes the items listed below:

- One power source
- Handsets and/or headsets
- Any number of jack receptacles or permanent handset stations
- One twisted-pair transmission wire

Handsets and headsets contain high-efficiency earpieces, noise-canceling microphones, and integrated circuit dual operational amplifiers with anti-sidetone circuitry, all to optimize operation in high-noise environments. The power to operate the handsets and headsets is applied to the same transmission wires used for talking. The power comes from a power source that features regulated voltage, current limiting, and a high output impedance.

The addition of one paging control wire to the transmission line, together with a two-way interface amplifier, allows the system to page into a Page/Party[®] system and support conversation both ways in a party-line mode.

The addition of one alarm control wire to the transmission line provides an isolated contact closure at the power source when any alarm connected anywhere along the transmission line is closed.

Power Source

The plug-in power source is powered by 115 volts ac, 50/60 Hz and supplies enough power to operate 15 handsets and/or headsets simultaneously. The output of the supply is regulated to a dc voltage of 8.8 volts nominal. The output current is limited so that under shorted line conditions the supply will deliver no more than 275 milliamps. The ac talking voltage, as well as the dc potential, appears across the output terminals of the supply. The overall size of the power source, including the enclosure, is approximately 8 inches × 8 inches × 5 inches deep. More than one power source may be used on one line to achieve long line connection with low loss.

Wiring that is foreign to the operation of the system shall not be associated in any way with the interconnection cable or wiring, nor shall it be fed into or through the enclosure or conduit. The enclosure and conduit shall not be used to ground any other piece of equipment.

Handsets and Headsets

Each handset and headset contains a dual operational amplifier (op-amp). One op-amp boosts the output of the noise-canceling dynamic microphone up to the level required for proper line transmission; the other op-amp provides power to the earpiece in sufficient amount for use in high-noise environments. An anti-sidetone circuit is used in the transmitting amplifier, so that voice and ambient noise signals do not reach the receiving amplifier of the same handset or headset, while incoming line signals from other handsets or headsets do reach the receiving amplifier.

The transmitting amplifier is a constant current device, and therefore, the handsets will drain approximately 12 milliamps from the power source even though the line voltage may be down to 3 volts at the end of a long line.

The headsets are designed to wear with or without a hardhat. They are equipped with a paging switch and a three-circuit cord and plug. The headsets will operate in a paging or non-paging system without modification.

Extension Cables

The headsets have short cords, and therefore, require extension cables to allow movement in and about the area of the jack station. This arrangement also allows a user to disconnect their headset from the circuit without losing the ear protection in noisy environments. The 30-foot cable has a belt clip 2 feet from the headset end to prevent any strain from reaching the headset. The cable will readily disconnect from the headset when undue strain occurs.

Temporary Transmission Lines

It is possible to create a temporary transmission line by connecting a number of extension cables in a series arrangement until the desired distance is reached. Up to 15 handsets and/or headsets can be in use simultaneously using a number of temporary transmission lines of this type.

Transmission Lines

One twisted pair is required for basic system operation. One additional conductor is required for the paging option. Another additional conductor is required for the alarm option. The alarm option is independent of the page option, so that the system can be used with any combination of the options.

Wire size should be considered carefully because of the low initial dc voltage. Generally, long lines require heavier wire than short lines. Lines may be installed radially from the power source, looped for redundant feed, or installed using a combination of both radial and loop. See Figure 1 for typical radial arrangements.

Interconnecting cables for Electro-Sound should not include any conductors foreign to the system. The transmission line must be excluded from any cabling, conduit, or cable trays containing power circuits when requirements are to minimize electrical noise pickup.

Jack Receptacles

For convenience, any quantity of receptacles can be used in a system; they can be arranged in groups or installed singly. The standard configuration is a Jack Station Plate Assembly mounted on a single gang weatherproof receptacle box. When the paging option is used, the cover plate must be made of insulating material. The sleeve of the plug circuit shall not be grounded, or the page function will not operate properly. The overall size of the jack station is approximately 3 inches × 3 inches × 6 inches.

Wiring the system is very simple. All jacks are connected in parallel, properly observing identification markers found near the terminal blocks on the rear of the Jack Station Plate Assemblies. Wiring that is foreign to the operation of the system shall not be associated in any way with the interconnecting cable or wiring, nor shall it be fed into or through the boxes housing any Electro-Sound equipment. The boxes and conduit shall not be used to ground any other piece of equipment.

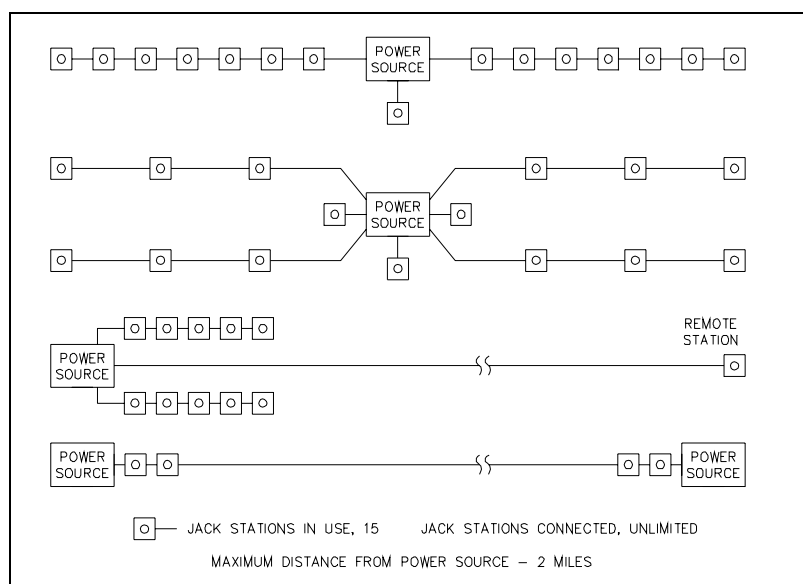

Figure 1.

Permanent Stations

A permanent station has a permanently wired-in handset with a hook-switch to disconnect it from the transmission line when it is placed on the hook (called an *on-hook* condition). These stations also have the capability of muting a monitor speaker or a local page speaker.

There are three types of permanent stations:

- *Permanent Indoor Station:* These stations are approximately 12 inches (H) × 9 inches (W) × 4 inches (D).
- *Permanent Flush-mount Station:* These stations are approximately 13 inches (H) × 4 feet (W) × 7 inches (D). See Figure 2.
- *Permanent Outdoor Station:* These stations are constructed of structural foam polycarbonate and are approximately 15 inches (H) × 12 inches (W) × 11 inches (D). See Figure 3.

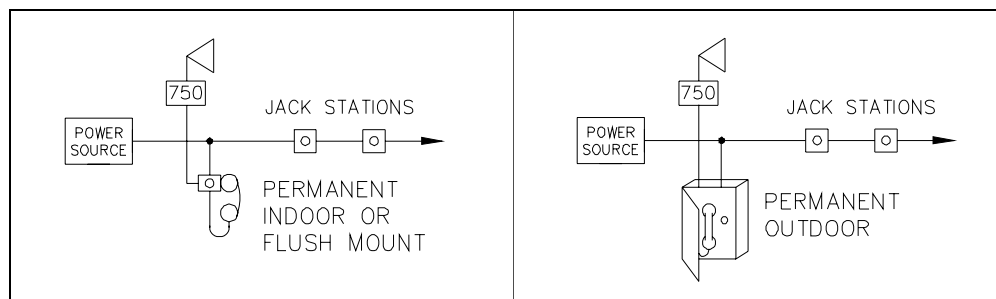

Figure 2.

Figure 3.

Monitor Speaker

A Model 750 or Model 760 Series Speaker Amplifier can be used to drive a monitor speaker. The amplifier can be used in two ways. When used with a non-paging system, the amplifier is connected to the transmission line through a 0.22 mFd/80 volt capacitor. When used this way, the speaker will reproduce everything that appears on the transmission line.

When used in a paging system, the speaker amplifier is connected to the page circuit of the power source through a 0.22 mFd/80 volt capacitor. When used in this way, the speaker reproduces signals that appear on the transmission line when the paging button is pressed. Up to 2 amplifiers may be connected in either fashion without using an interface. The amplifier is powered by 115 V ac volts 50/60 Hz and can deliver 12 watts into the speaker, which may be 8- or 16-ohm impedance. See Figure 4 and Figure 5.

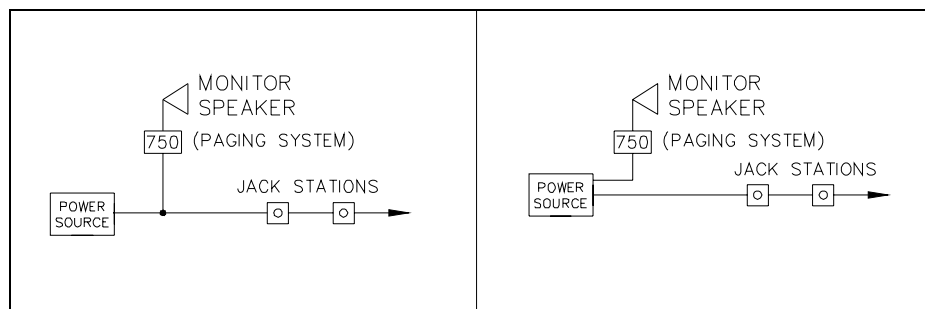

Figure 4.

Figure 5.

Two-System Interfacing

Electro-Sound can be connected to a Page/Party[®] system by means of a Model 370-202 Interface. The interface amplifier will match the Electro-Sound transmission line operating at 1000 ohms and one volt ac and a Page/Party[®] system operating at 33 ohms and one volt ac. Gain is adjustable in either direction and is factory adjusted before shipment. A line balance control is included and should be adjusted once at the time of system start-up.

Interconnecting wires include: one twisted pair for ac power, 115 volts, 60 Hz; one twisted pair for page; one twisted pair for party; and one twisted pair for Electro-Sound. Minimum wire size should be No. 14 AWG for the power and No. 18 AWG for the others. The interface should be located within 300 feet of the line balance assembly of the Page/Party[®] system. See Figure 6.

The twisted pair for the Electro-Sound shall be kept separated from the other wiring in the enclosure, and it shall not be included in any conduit, cable, or cable tray with the other wiring in the enclosure. Wiring foreign to the operation of the system shall not be associated in any way with the interconnecting cable or wiring, nor shall it be fed into or through the interface enclosure. The interface enclosure and conduit shall not be used to ground any other piece of equipment.

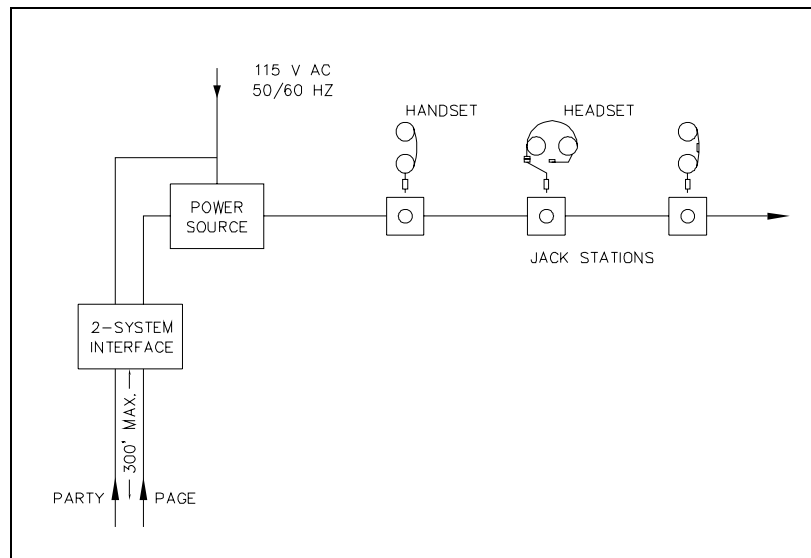

Figure 6.

Installation

This section concerns installation of an Electro-Sound system. It contains considerable detail on the power source location, minimum wire size, and maximum line-length vs. number of stations in use. There are five main points to planning and installing:

- The power source should be located near the electrical load center of the system.
- Use cable with twisted conductors.
- Use the appropriate wire size.
- Do not locate the cable in same conduit or cable tray used for power wiring.
- Do not attempt to operate more than 15 handsets, headsets, or permanent stations at any one time. This is due to current limiting within the power source and does not limit the number of jack stations that might be installed.

Two-Wire System with Optional Monitor Speaker

A basic Electro-Sound system provides communications between 2 to 15 handsets or headsets tied to one pair of wires. Such a system can be interconnected as shown in Figure 7. This diagram also shows an optional monitor or call-in speaker system for the dispatcher or supervisor.

The system provides a monitor and/or call-in speaker that may be mounted in the vicinity of the dispatcher or supervisor station. The input to the speaker amplifier is muted when the handset of that station is removed from its hook. If muting is not desired, omit the red wire in the three-conductor cable attached to that station, and install a wire link between terminals 7 and 11 in the power source enclosure.

Only one permanent station and one jack station are shown for drawing simplicity. There is no limit to the number of stations that can be installed in a system. However, the power source is current-limited to 15 operating stations.

Suggested wire colors are shown to aid in connection identification. The stations will not function if polarity is reversed. Cables to and between stations must be kept separate from the power source.

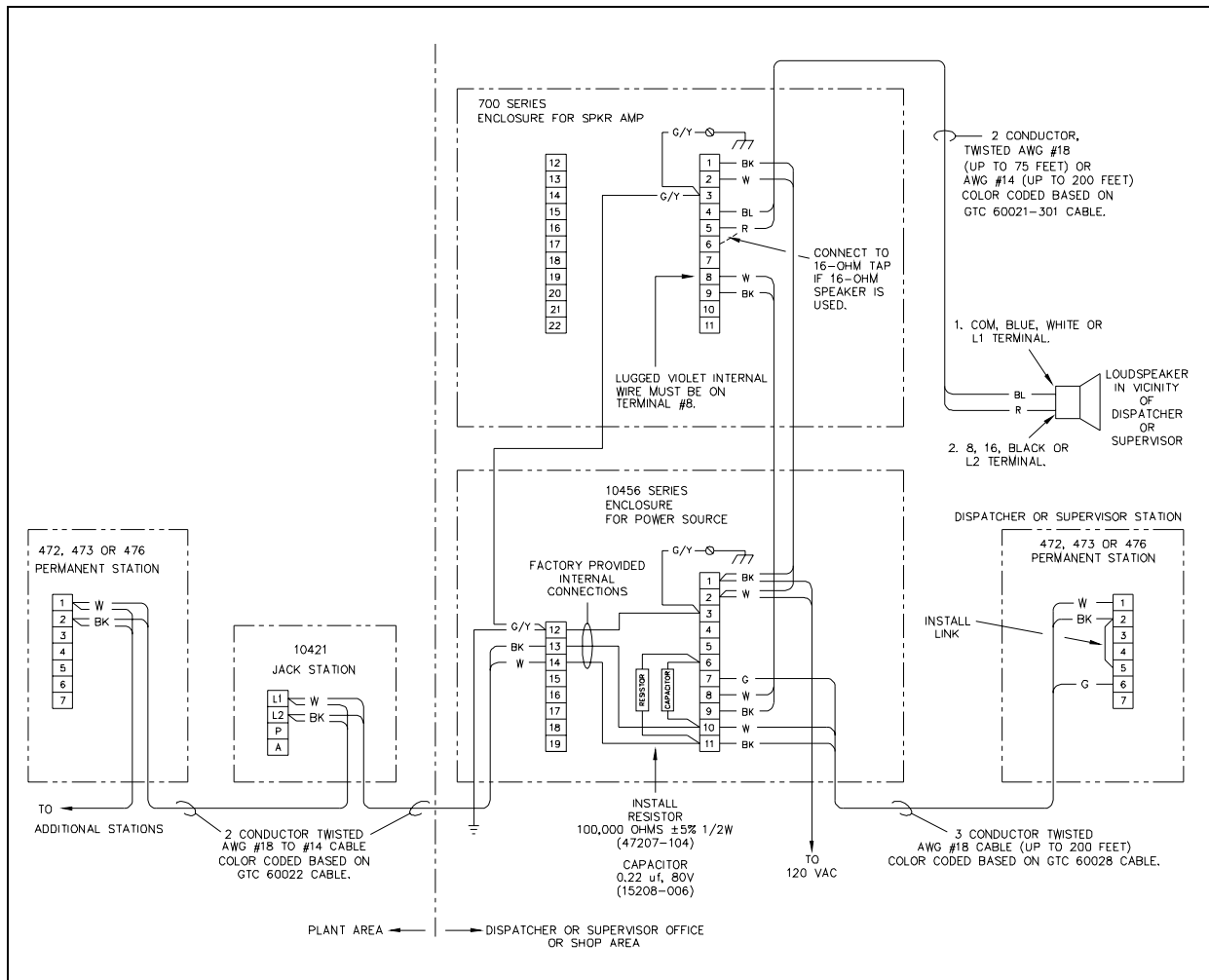

Figure 7. Typical 2-wire System with Monitor Speaker

Three-Wire System with Paging Speakers

With a third conductor in the cable between stations and connected to the power source, pressing the push-switch on any handset or headset in the system will connect the signal line to a paging amplifier system. Figure 8 shows a simplified system using a GAI-Tronics speaker amplifier. One or two additional amplifiers may be connected if needed.

Paging speakers located near jack stations must be positioned to minimize the possibility of acoustic-feedback when page calls are made from the handset or headset plugged into that station. Paging speakers in close proximity to permanent stations may be wired to the hook-switch of the station. This mutes the speaker when the handset is off the hook and prevents acoustic feedback.

Only one jack station and two permanent stations are shown in Figure 8 for drawing simplicity. The power source is current-limited to 15 operating stations. Suggested wire colors are shown to aid in connection identification. The stations will not function if the polarity is reversed. Cables to and between stations must be kept separate from power cables.

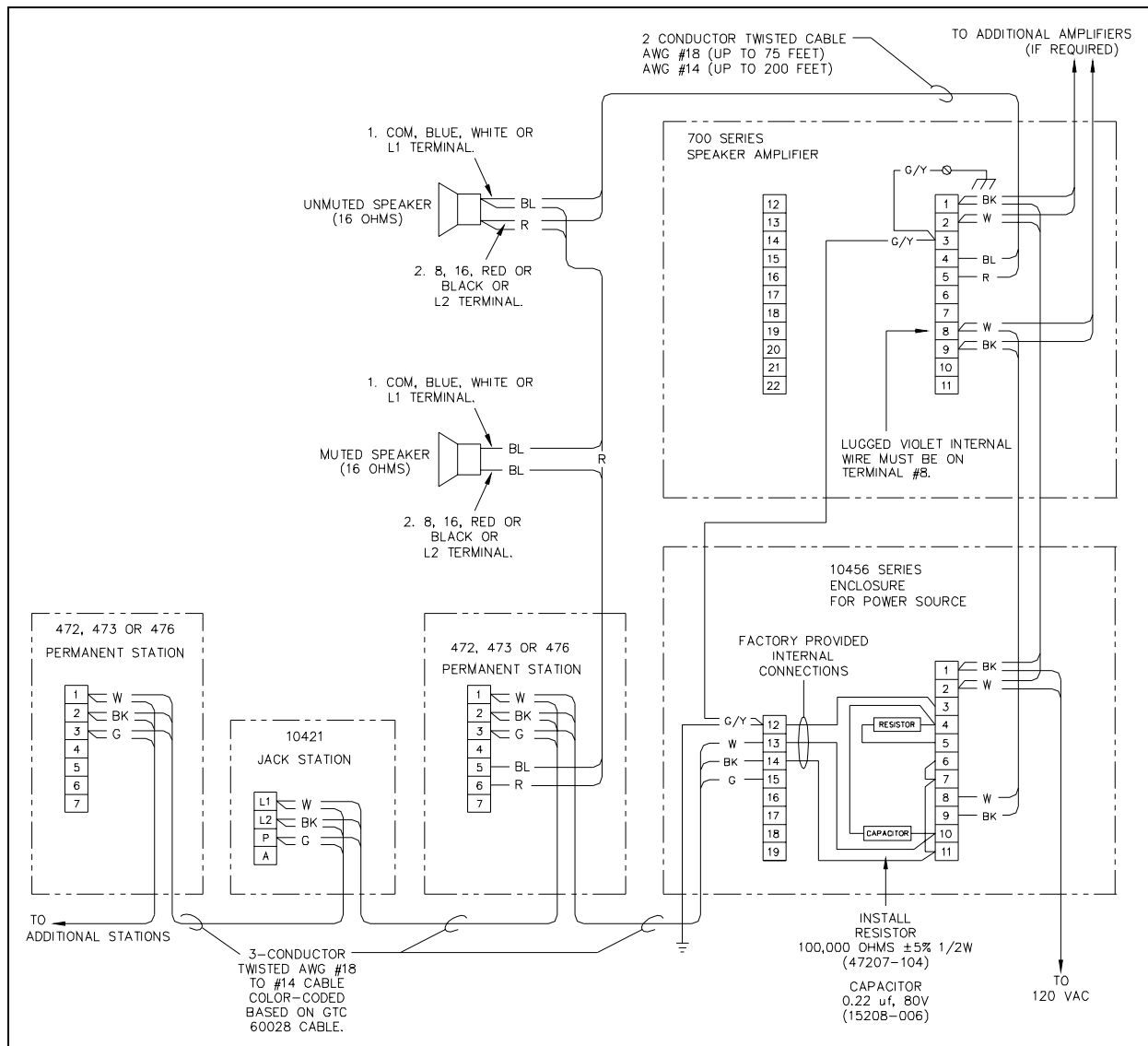

Figure 8. Typical Three-wire System with Paging Speakers

Coupling Electro-Sound to a GTC Page/Party® System

A GAI-Tronics two-way amplifier, consisting of a Model 371-202 Plug-In Amplifier and a suitable 372 Series enclosure, is used to interface an Electro-Sound system and a Page/Party® system. For wiring convenience, the two-way amplifier should be adjacent to the Electro-Sound power source; however, it also must be located within 300 feet of the Page/Party® system line balance assembly. Also, it will be convenient for test purposes to have all the above next to a Page/Party® system wall station.

Figure 9 shows the wiring of a three-wire Electro-Sound system interfaced to a five-party Page/Party® system. The handsets or headsets plugged into jack stations are tied to party line five but switch to the page line whenever the page switch on the handsets or headsets is pushed. The power source contains a relay that disconnects the coupling when no handset or headset is plugged in and another relay for switching between page and party lines. The wiring shown in Figure 9 provides ac power to the power source and interface amplifier from the power source for the Page/Party® system wall station.

The interface wiring shown in Figure 9 can be used for two-wire Electro-Sound systems and/or situations requiring coupling to page or party lines (but not both). It is absolutely necessary to place a 33-ohm load between points four and five or between points six and seven on the power source enclosure terminal blocks if these points are not connected to a page or party system. The two-way amplifier may oscillate if these resistors or the Page/Party® system line balance assembly is not connected.

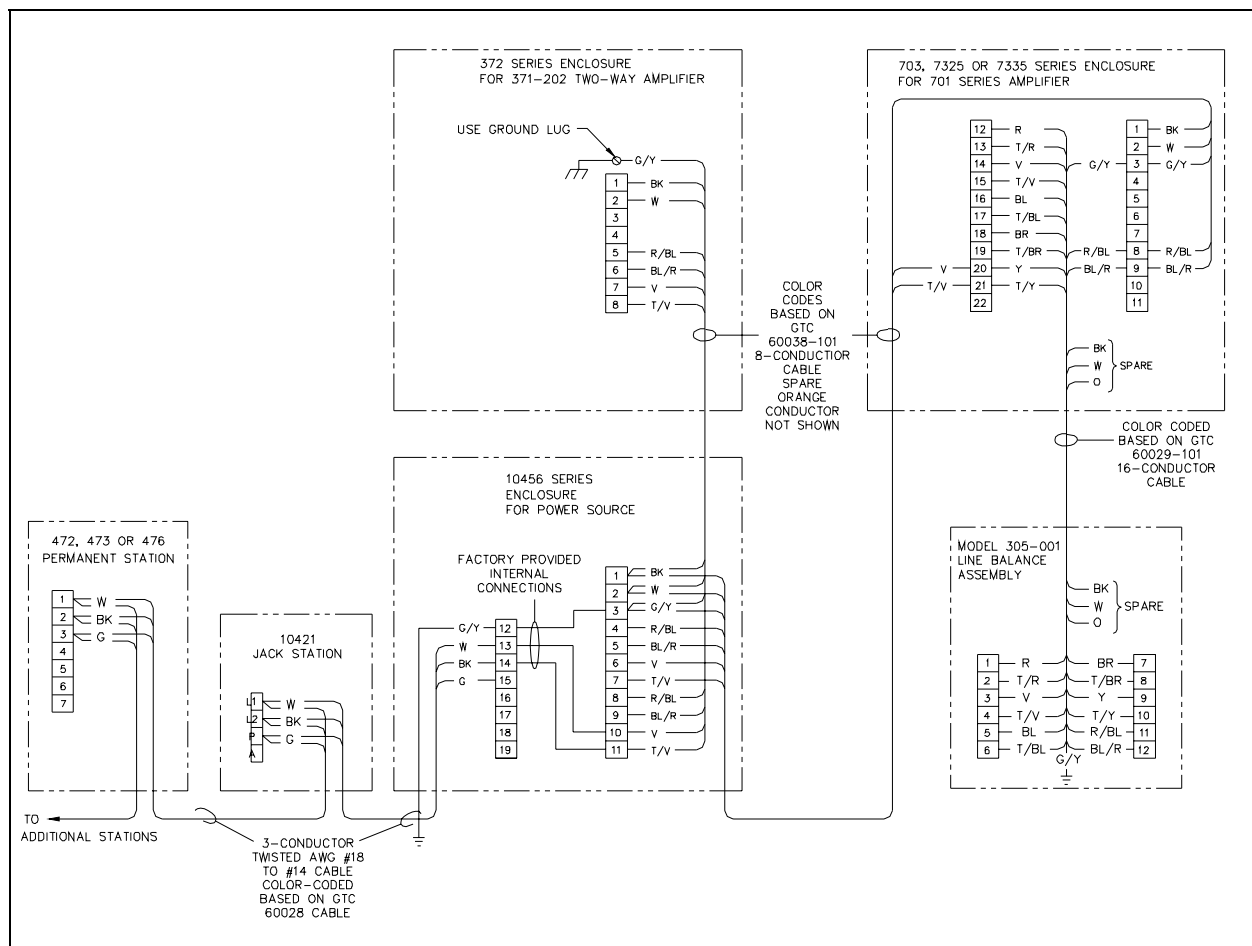

Figure 9. Typical Electro-Sound System with GTC Page/Party® System Interface

This system provides coupling with a Page/Party[®] system. The Electro-Sound system is shown coupled to party line 5 but can be coupled to any other party line as desired. Switching between page and party lines is controlled by Electro-Sound handset and headset switches. The power source contains a relay to isolate systems when no handset or headset is in use.

Only one jack station and one permanent station are shown for drawing simplicity. The power source is current-limited to 15 operating stations.

Suggested wire colors shown to aid in connection identification. The stations will not function if polarity is reversed. Cables to and between stations must be kept separate from power cables.

NOTE: An existing Page/Party[®] system should already have a line balance assembly. It is shown here in the event it is relocated to be within 300 feet of the two-way amplifier as recommended.

List of Assemblies	
370-202 Page/Party [®] Electro-Sound Interface	760-001 Outdoor Speaker Amplifier
471-101 Power Supply	10410-002 30-foot Headset Extension Cable
472-001 Indoor Handset Station	10421-002 Jack Station Cover Plate
473-001 Outdoor Handset Station	10439-101 Safety Barrier
475-002 Weatherproof Jack Station	10450-202 Amplified Handset Assembly, 6-foot Coil Cord
476-001 Flush Mount Handset Station	10453-401 Headset/Microphone
750-401 Indoor Speaker Amplifier	21202-001 Jack Unit