



GAI-TRONICS® CORPORATION
A HUBBELL COMPANY

Industrial Communications System Page/Party® Flush-Mount Subset

General Information

Product Overview

The GAI-Tronics Industrial Communications System (ICS) Page/Party® is a modular industrial communications system that can include from two to possibly hundreds of stations. All stations are wired in parallel and additional stations can be added to the system at any time.

The flush-mount subset enables you to perform page and party line communication when installed with a remote amplifier. The rugged remote subset includes a pressbar handset, a handset cradle, and a five-party rotary selector switch (multi-party subset only).

The flush-mount subset is designed for recessed installation in a wall or console. The compact size is made possible by housing most of the support electronics in a separate remote amplifier.

The subset is designed for indoor flush-mount applications. The DB25 subset interconnect cable permits mounting up to 10 feet from the amplifier.

Features

- Provides one-way page announcements over system speakers
- Provides full-duplex party line communication
- Durable, high visibility safety orange powder coat finish

Options

- Single party line operation
- PVC or Hytrel® handset cords in 6-, 15-, or 25-foot lengths
- Conformal coating for PCBA

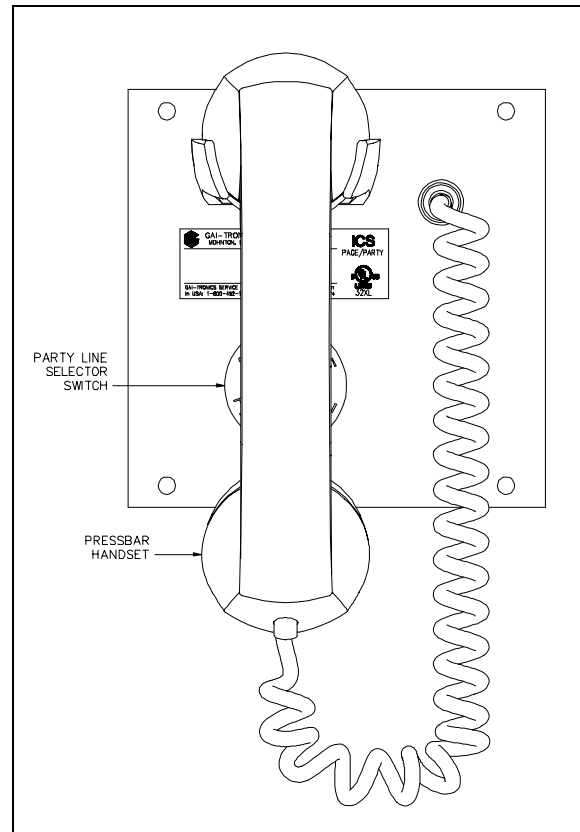

Figure 1. ICS Multi-Party Flush-Mount Subset

Installation

! WARNING ! Do not install this equipment in hazardous areas. Such installations may cause a safety hazard and consequent injury or property damage.

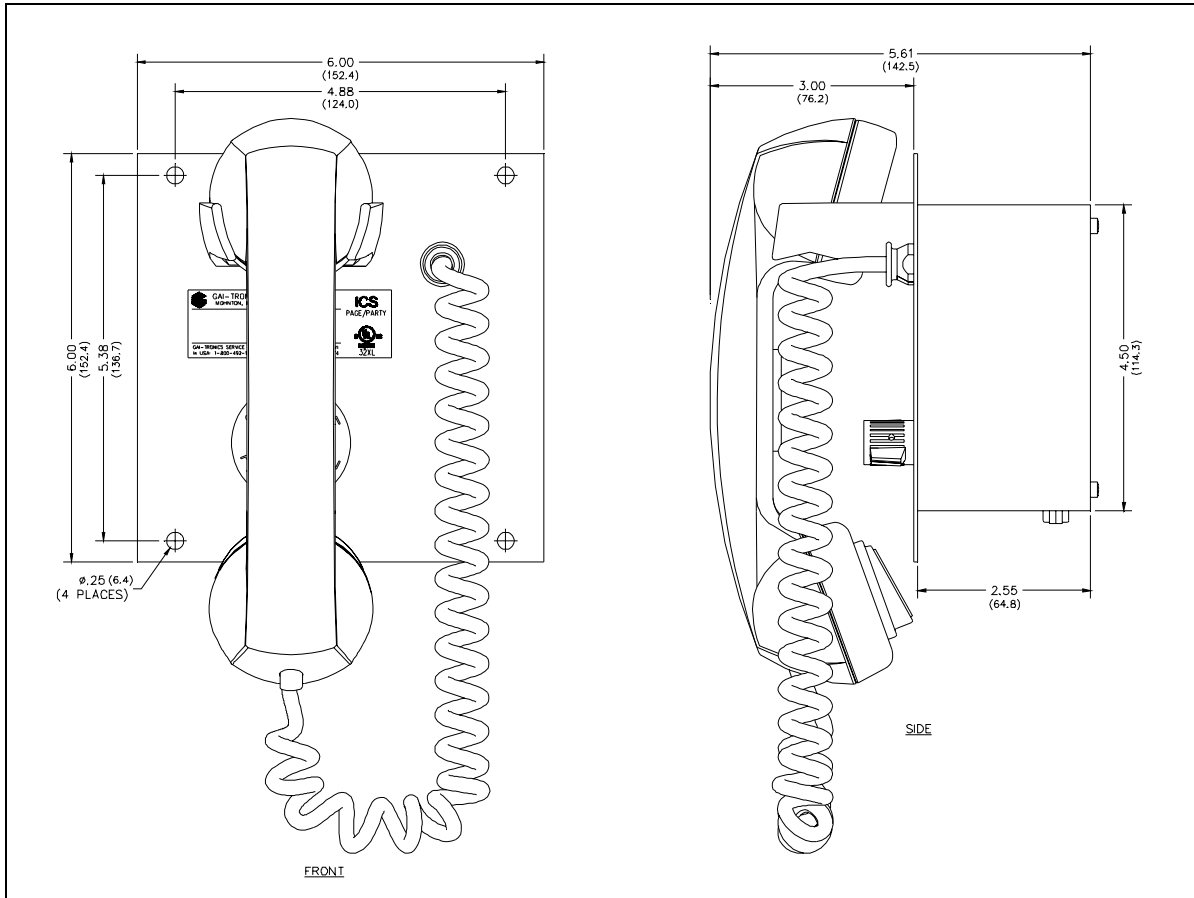

Figure 2. ICS Multi-Party Flush-Mount Subset Outline

1. Refer to Figure 2 for the subset mounting hole locations and overall sizes. Refer to Figure 3 for cutout dimensional requirements.
2. Plug the interconnect cable into the remote subset. Feed the opposite end of the cable into the mounting cutout to the remote amplifier location.
3. Secure the subset to the mounting surface using four #10-32 screws and the mounting holes. Refer to Figure 4 for a typical installation.
4. Plug the subset interconnect cable into the remote amplifier.

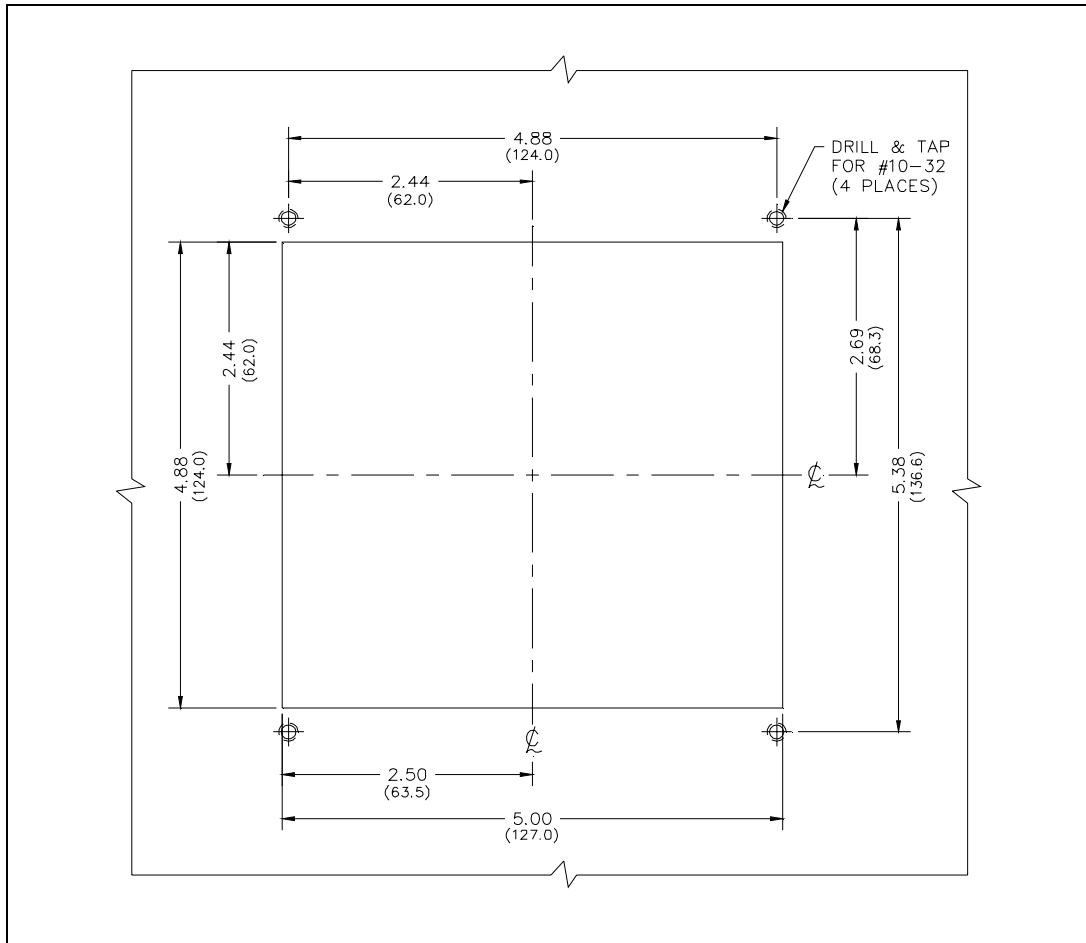

Figure 3. Flush-Mount Cutout Detail

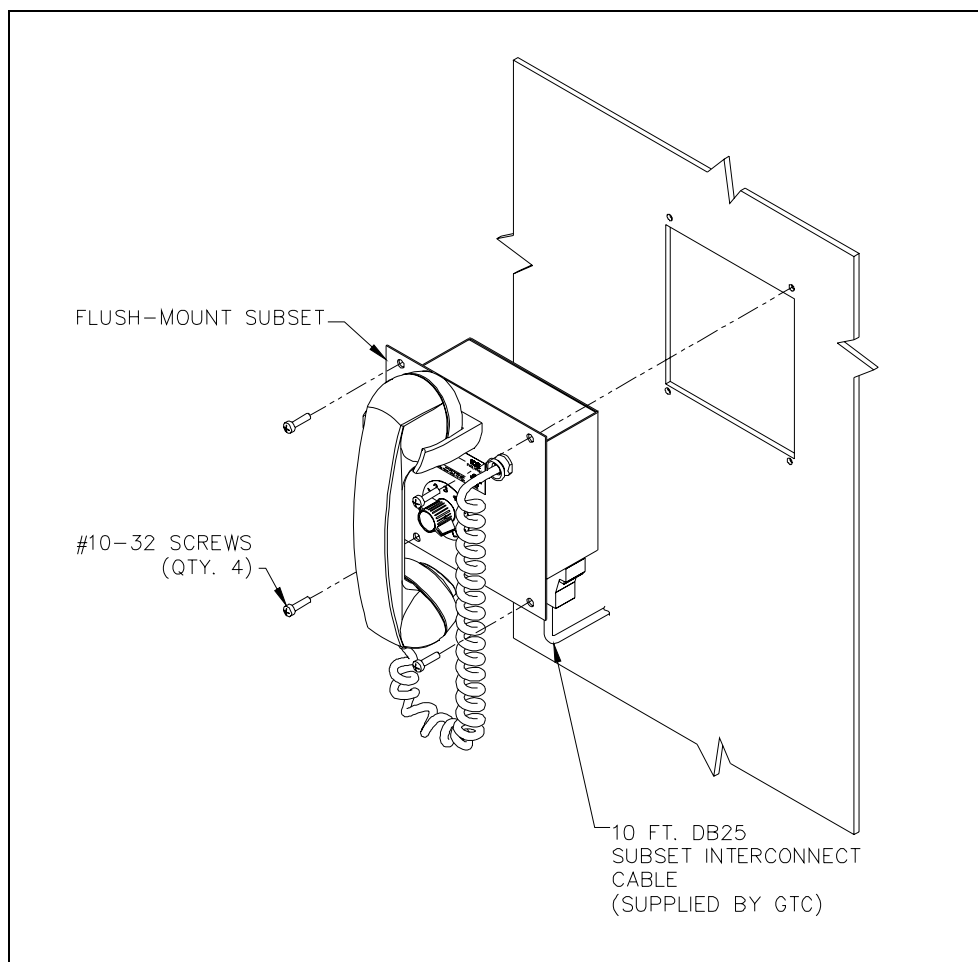

Figure 4. Typical Flush-Mount Installation

Operation

For paging and subsequent party line conversation, the station operator lifts the handset, selects a free party line using the five-position rotary selector switch (if equipped), and presses the handset pressbar. The station operator pages the desired individual and designates the party line on which that individual should respond. The individual then responds by approaching the nearest ICS Page/Party® station, selecting the appropriate party line and lifting the handset. Full-duplex communication can then be held on the party line without broadcasting over the speakers. After the conversation is complete, all parties should place the handset back on hook.

NOTE: The ICS Page/Party® station incorporates a noise-canceling microphone to reduce transmitted ambient noise. This requires the user to place the microphone as close as possible to his or her mouth.

Troubleshooting

The following table is provided to aid qualified service personnel in troubleshooting problems with the ICS Page/Party® subset.

Problem	Potential Cause
Subset is not functional.	<ul style="list-style-type: none"> • Verify DB25 Interconnect cable is properly terminated between the subset and remote amplifier. • Refer to general troubleshooting section in ICS Page/Party® Remote Handset/Speaker Amplifier manual for adjustments and settings that affect ICS subset operation.

Specifications

Handset

Microphone.....	Dynamic, noise-canceling
Receiver.....	Dynamic, hearing aid compatible
Cord.....	Retractable, 6-foot extended, PVC
Material.....	ABS
External control.....	Push-to-page handset pressbar

Subset Specifications

Construction/finish.....	16-gauge cold-rolled steel/safety orange powder coat
Mounting.....	Flush-mount or similar location; four 0.25-inch (6.3 mm) mounting holes
Cutout dimensions.....	5.00 W × 4.88 H × 2.6 D inches (127 × 124 × 66 mm)
Front panel dimensions.....	6.00 H × 6.00 W inches (152.4 × 152.4 mm)
Shipping weight.....	4.75 lbs. (2.2 kg)
Net weight.....	2.75 lbs. (1.2 kg)

Environmental

Temperature range (operation and storage).....	-22° F to 158° F (-30° C to 70° C)
Humidity.....	95% non-condensing

Approvals

NRTL certified for use in US and Canada.....	UL/CSA 60950
--	--------------

Warranty

Equipment. GAI-Tronics warrants for a period of one (1) year from the date of shipment, that any GAI-Tronics equipment supplied hereunder shall be free of defects in material and workmanship, shall comply with the then-current product specifications and product literature, and if applicable, shall be fit for the purpose specified in the agreed-upon quotation or proposal document. If (a) Seller's goods prove to be defective in workmanship and/or material under normal and proper usage, or unfit for the purpose specified and agreed upon, and (b) Buyer's claim is made within the warranty period set forth above, Buyer may return such goods to GAI-Tronics' nearest depot repair facility, freight prepaid, at which time they will be repaired or replaced, at Seller's option, without charge to Buyer. Repair or replacement shall be Buyer's sole and exclusive remedy. The warranty period on any repaired or replacement equipment shall be the greater of the ninety (90) day repair warranty or one (1) year from the date the original equipment was shipped. In no event shall GAI-Tronics warranty obligations with respect to equipment exceed 100% of the total cost of the equipment supplied hereunder. Buyer may also be entitled to the manufacturer's warranty on any third-party goods supplied by GAI-Tronics hereunder. The applicability of any such third-party warranty will be determined by GAI-Tronics.

Services. Any services GAI-Tronics provides hereunder, whether directly or through subcontractors, shall be performed in accordance with the standard of care with which such services are normally provided in the industry. If the services fail to meet the applicable industry standard, GAI-Tronics will re-perform such services at no cost to buyer to correct said deficiency to Company's satisfaction provided any and all issues are identified prior to the demobilization of the Contractor's personnel from the work site. Re-performance of services shall be Buyer's sole and exclusive remedy, and in no event shall GAI-Tronics warranty obligations with respect to services exceed 100% of the total cost of the services provided hereunder.

Warranty Periods. Every claim by Buyer alleging a defect in the goods and/or services provided hereunder shall be deemed waived unless such claim is made in writing within the applicable warranty periods as set forth above. Provided, however, that if the defect complained of is latent and not discoverable within the above warranty periods, every claim arising on account of such latent defect shall be deemed waived unless it is made in writing within a reasonable time after such latent defect is or should have been discovered by Buyer.

Limitations / Exclusions. The warranties herein shall not apply to, and GAI-Tronics shall not be responsible for, any damage to the goods or failure of the services supplied hereunder, to the extent caused by Buyer's neglect, failure to follow operational and maintenance procedures provided with the equipment, or the use of technicians not specifically authorized by GAI-Tronics to maintain or service the equipment. **THE WARRANTIES AND REMEDIES CONTAINED HEREIN ARE IN LIEU OF AND EXCLUDE ALL OTHER WARRANTIES AND REMEDIES, WHETHER EXPRESS OR IMPLIED BY OPERATION OF LAW OR OTHERWISE, INCLUDING ANY WARRANTIES OF MERCHANTABILITY OR FITNESS FOR A PARTICULAR PURPOSE.**

Return Policy

If the equipment requires service, contact your Regional Service Center for a return authorization number (RA#). Equipment should be shipped prepaid to GAI-Tronics with a return authorization number and a purchase order number. If the equipment is under warranty, repairs or a replacement will be made in accordance with the warranty policy set forth above. Please include a written explanation of all defects to assist our technicians in their troubleshooting efforts.

Call 800-492-1212 (inside the USA) or 610-777-1374 (outside the USA) for help identifying the Regional Service Center closest to you.