



GAI-TRONICS® CORPORATION  
A HUBBELL COMPANY

# Model 491-204

## Mine Dial/Page Telephone

---

### Confidentiality Notice

This manual is provided solely as an operational, installation, and maintenance guide and contains sensitive business and technical information that is confidential and proprietary to GAI-Tronics. GAI-Tronics retains all intellectual property and other rights in or to the information contained herein, and such information may only be used in connection with the operation of your GAI-Tronics product or system. This manual may not be disclosed in any form, in whole or in part, directly or indirectly, to any third party.

### General Information

The GAI-Tronics Mine Dial/Page Telephone system combines the convenience of a telephone station with paging capabilities in gaseous or dusty locations too hazardous for standard telephone equipment. The system is rated as “permissible” for use in gassy coal mines by the Mine Safety and Health Administration (MSHA) of the United States Department of the Labor (Approval Number 9B-221).

The system is used in conjunction with a touch-tone (also known as dual-tone multi-frequency [DTMF]) operated public telephone exchange or a private branch exchange (PBX). Each station in the system is made up of two components:

- Mine Dial/Page Telephone
- Interface assembly mounted outside the hazardous area

The interface assembly is electrically connected between the station and the telephone switchboard. Each interface assembly is connected to a separate line of the telephone exchange.

### Features

The GAI-Tronics Model 491-204 Mine Dial/Page Telephone system is designed as an alternative to the mine pager system and other communication systems (such as the “Pager” or “Loud-Speaking Telephone”) that lack privacy and multiple conversation capabilities. The GAI-Tronics Mine Dial/Page Telephone system includes the following features:

- Each station has a separate line. The number of independent, simultaneous conversations is limited only by the number of stations and the capacity of the PBX.
- Stations inside the hazardous area can call any telephone outside the area, as well as any other Mine Dial/Page Telephone station within the area.

- Automatic circuits in the Mine Dial/Page Telephone “answer” incoming calls and permit the calling party to page the desired person using a self-contained horn-type loudspeaker. This voice page is preceded by a distinctive tone and is accompanied by a flashing light to assist in locating the telephone in dark areas. The flashing light also gives visual notice of the call in high-noise areas. The flashing light complies with Virginia and West Virginia MSHA regulations.
- A person initiating a call can page someone at a specific location without disturbing personnel at other locations.
- The All-Call function pages all the stations simultaneously while also reaching those stations using the system for normal conversations.
- The push button controlled, all-station page operation is activated automatically in the event of a telephone switchboard failure.

A single pair of wires connects each Mine Dial/Page Telephone to the interface assembly. Each interface is connected to the telephone switchboard with another corresponding pair of wires.

A person using a Mine Dial/Page Telephone station can access any station or any conventional telephone connected to that switchboard. If the switchboard is tied into the public telephone system, an individual can call out or receive calls from any public telephone.

Personnel in hazardous areas have direct contact to all non-hazardous areas with extension telephones without the purchase of additional communications equipment for these non-hazardous areas.

In keeping with MSHA regulations, at least one GAI-Tronics Model 491-204 Mine Dial/Page Telephone Station for each interface cabinet must be installed outside of a coal mine.

# Equipment Description

The GAI-Tronics Mine Dial/Page Telephone system can be configured to meet individual customer needs. A single interface cabinet can support up to 80 Model 69001 Mine Dial/Page Telephone Station Line Interface Cards within the Model 495-001 Mine Dial/Page Telephone Interface Cabinet. See Figure 1 for a typical system configuration and guidelines on cabling. Refer to Pub. 42004-198 for installation and cabling of the Model 495-001 Interface Cabinet.

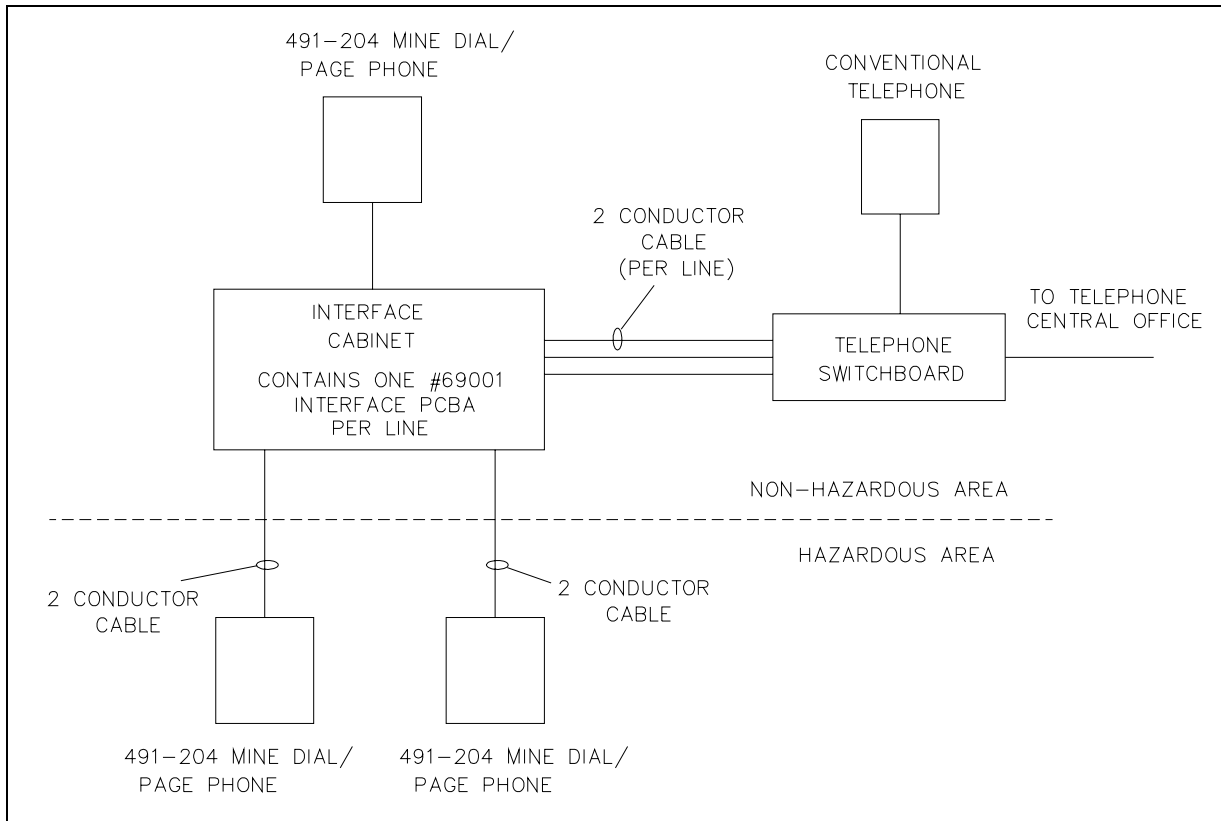

Figure 1. Typical System Configuration

The Model 491-204 Mine Dial/Page Telephone is contained within a corrosion-resistant, non-metallic enclosure measuring approximately 13 × 10 × 7 inches (330 × 254 × 178 mm), not including the handset. The handset is located in a cradle mounted to the top of the enclosure. This cradle doubles as a carrying handle.

The mounting and overall dimensions of the Model 491-204 Mine Dial/Page Telephone are shown in Figure 2. This figure details many features of these stations such as the horn-loaded loudspeaker, telephone keypad, emergency page push button, weatherproof seals, and stainless steel hardware.

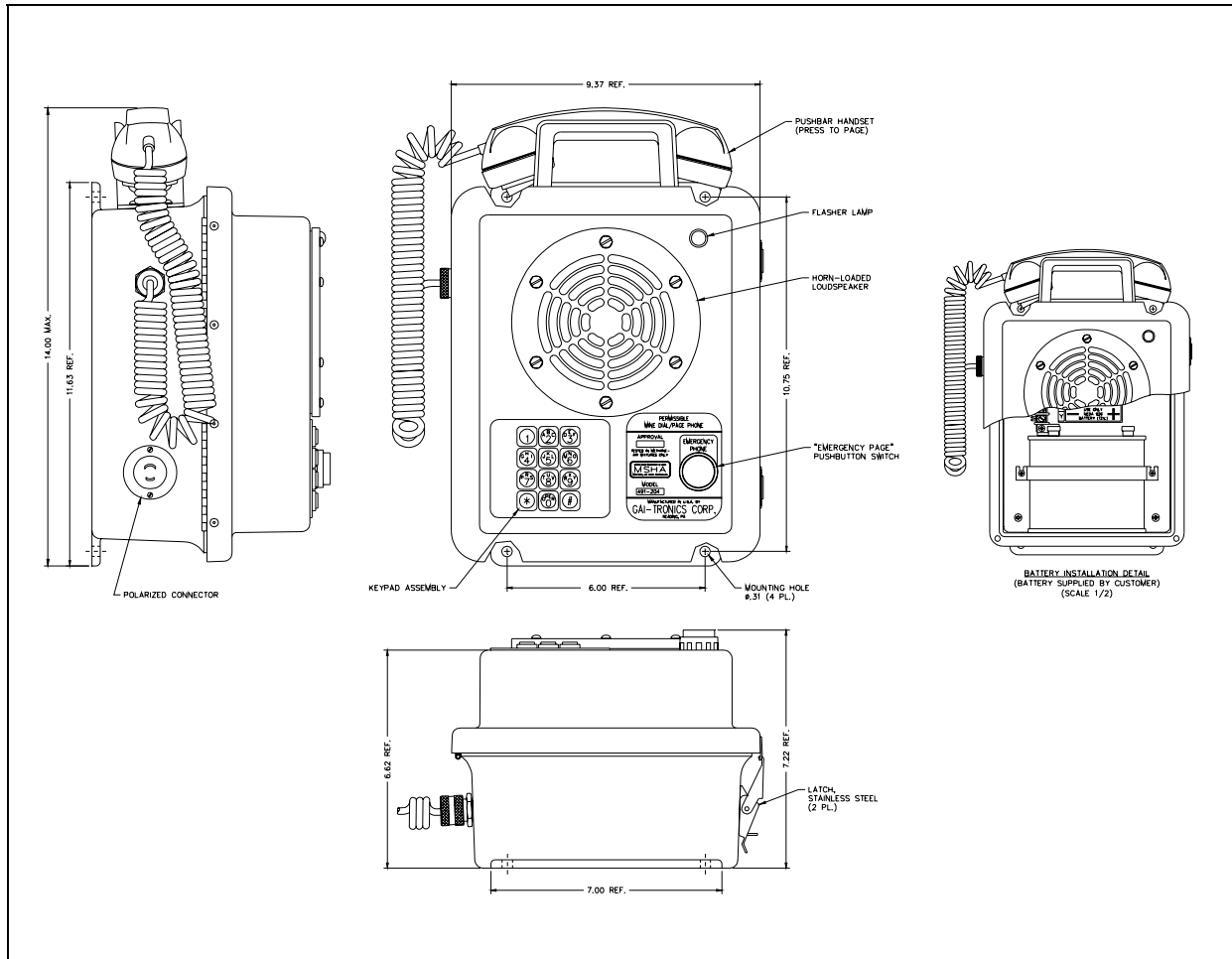

Figure 2. Mounting and Overall Dimensions of Model 491-204

A pressbar switch is built into the handset and must be pressed whenever the station is in use—both talking *and* listening. This control replaces the conventional hang-up hookswitch, eliminating the possibility of a user leaving the station off-hook and thereby unable to receive pages.

Most of the electronic circuitry is located on a single plug-in PCBA, GAI-Tronics Model 69491-401, inside the Model 491-204 Station. The circuitry associated with keypad and sidetone adjustment is located on a small PCBA behind the keypad (Model 69491-002). All these circuits operate from a single 12 V NEDA 926 lantern battery also contained within the station. These internal components are shown in Figure 3.

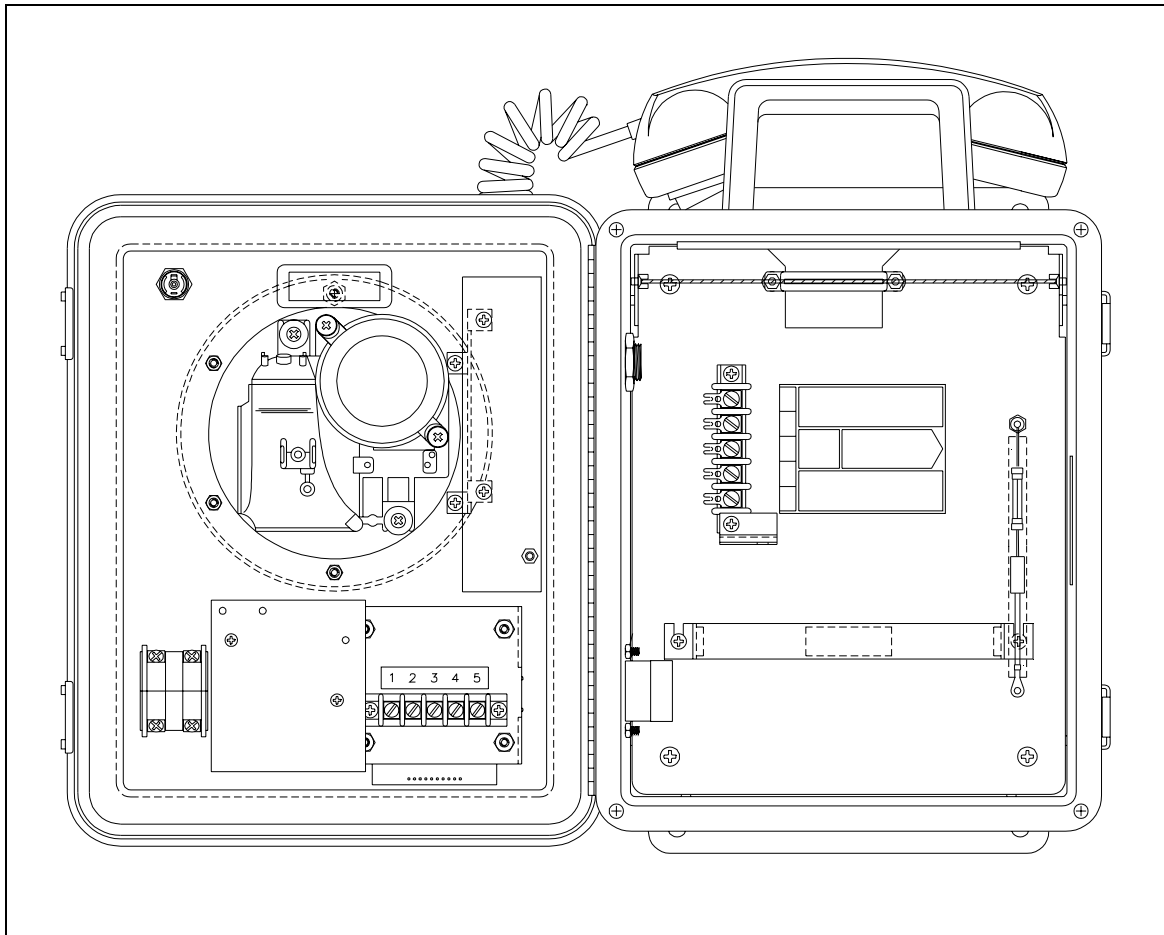

Figure 3. Internal Components

For each Mine Dial/Page Telephone station, a GAI-Tronics Model 69001-001 Interface PCBA must be used. This assembly is a plug-in printed circuit board measuring approximately 7.5 × 4.5 inches (190.5 × 114 mm) and must be mounted in a non-hazardous area within a Model 495-001 Mine Dial/Page Telephone Interface Cabinet.

# Installation

Mount the Model 491-204 Mine Dial Telephone Station in a location where the handset can be reached and where it is sufficiently visible. Four holes are provided for mounting to a wall or panel.

## Wiring Connections

Connect the Model 491-204 Mine/Dial/Page Telephone to the card rack in the interface assembly as follows:

- Connect the L1 wire from the interface cabinet's card rack to the telephone's wide or silver-colored terminal on the twist-lock plug.
- Connect the L2 wire from the interface cabinet's card rack to the narrow or gold-colored terminal. A rubber boot with a twist-lock connector mates with the connector on the station. This boot is installed to form a seal to the station enclosure.

While each underground station will have a telephone extension number, that number is associated with the line rather than the actual station.

*For Example:* If two separately connected stations at locations A and B are interchanged, the unit brought from location B to location A will respond to the same telephone extension number as the original unit at location A. Therefore, the telephone extension number should be marked at the location and not on the unit.

A NEDA 926 Battery (12 V) must be installed in the enclosure. To install the battery, remove the battery hold-down bracket.

1. Connect the battery's red wire to the positive terminal, and the green wire to the negative terminal.
2. Two brackets on the station are positioned so that the battery can only be installed in one direction. The bracket terminal posts must be loosened to install the battery. When the battery is installed, remember to re-tighten these posts.
3. Finally, reinstall the battery hold-down bracket.

# Operating Instructions

## Answering Incoming Calls

1. Wait until the “birdie” call stops, and allow the calling party sufficient time to announce the desired person’s name.
2. Lift the handset from the cradle, and press the handset pressbar. Reply to the calling party. Do not release the pressbar at any time during conversation, or the conversation will be terminated.
3. Release the pressbar to terminate the call. Return the handset to the cradle.

## Initiating Calls

Calling Another Mine Dial/Page Telephone Station:

1. Press and hold the handset pressbar while listening for a dial tone.
2. Dial the desired telephone number.
3. Wait until the “birdie” signal stops, then page the desired person(s).
4. If no one answers after 30 seconds, terminate the call (the called person’s telephone connection returns to ready condition after 30 seconds).
5. Release the handset pressbar to terminate the call.

Paging All Mine Dial/Page Telephone Stations (All-Call):

1. Press and hold the handset pressbar while listening for a dial tone.
2. Dial the special (PBX) page number.
3. Immediately page the desired person(s), giving the message and call-back instructions (the paged person cannot answer directly).
4. Release the handset pressbar immediately.
5. Wait for the return call.

Calling a Standard Telephone Station:

1. Press and hold the handset pressbar while listening for a dial tone.
2. Dial the desired telephone number.
3. Wait until the called person answers, then talk.
4. Release the handset pressbar to terminate the call.

## Merge Mode

The system automatically transfers to this mode in the event of a switchboard failure.

1. Press and hold the handset pressbar; no dial tone will be heard.
2. Push and hold the EMERGENCY PAGE button.
3. Page the desired person(s).
4. Release the button, and wait for an answer.  
**NOTE:** Conversations are NOT private; any number of persons may use the party line simultaneously in the same conversation.
5. Release the handset pressbar to terminate the call.

## Flashing Page-Indicator Light

Automatic circuits “answer” incoming calls and permit the calling party to page the desired person using a self-contained horn-type loudspeaker. This voice page is preceded by a distinctive tone and is accompanied by a flashing light to assist in locating the telephone in dark areas. The flashing light also gives visual notice of the call in high-noise areas. The flashing light complies with Virginia and West Virginia MSHA regulations.

The flashing light circuitry connects to the mine dial/page telephone circuitry at only four points—the two battery binding-posts and the two loudspeaker connections. The audio signal at the speaker does not control the light. The dc level on both loudspeaker lines, with respect to the positive battery terminal, controls the light.

## Specifications

Line voltage .....	12 V dc
Supervisory current.....	20 mA dc maximum
Audio impedance, input.....	200 ohms, nominal
External controls (2) .....	Push-to-operate switch (in handset)/Emergency Page push button (on panel)
Internal controls (2) .....	Speaker volume adjustment; sidetone adjustment
Microphone.....	Dynamic, noise-canceling
Speaker.....	Dynamic, horn-loaded
Power supply.....	Internal dry cell battery, 12 volts
Page-indicator Lamp (optional) .....	66 flashes per minute; 6.6% duty cycle

### Typical Cable Characteristics

The table below defines cable size with cable characteristics to achieve increased operating distance and is dependant upon the type and quality of cable utilized, optimum cable line installation and PBX.

Cable Size	DC Resistance	Inductance	Capacitance (conductor to conductor)	Maximum Cable Length
No. 22 AWG	16.5 ohms per 1000 feet	Maximum 0.20 $\mu$ H/foot	Maximum 35 pF/foot	15,750 feet (~3 miles)
No. 18 AWG	7.1 ohms per 1000 feet	Maximum 0.20 $\mu$ H/foot	Maximum 35 pF/foot	31,500 feet (~6 miles)
No. 14 AWG	2.8 ohms per 1000 feet	Maximum 0.20 $\mu$ H/foot	Maximum 35 pF/foot	63,000 feet (~12 miles)

### Replacement Parts

Part Number	Description
10415-101	Handset Assembly
12502-101	Replacement Receiver Kit
12504-010	Keypad Replacement Kit - Models 491-103, 491-104, and 491-204
12506-003	Speaker Replacement Kit
12567-001	Page Switch
61507-009	Harness Assembly/Subset
69491-002	Keypad Amplifier PCBA
69491-401	Speaker Amplifier PCBA

# Warranty

---

Equipment. GAI-Tronics warrants for a period of one (1) year from the date of shipment, that any GAI-Tronics equipment supplied hereunder shall be free of defects in material and workmanship, shall comply with the then-current product specifications and product literature, and if applicable, shall be fit for the purpose specified in the agreed-upon quotation or proposal document. If (a) Seller's goods prove to be defective in workmanship and/or material under normal and proper usage, or unfit for the purpose specified and agreed upon, and (b) Buyer's claim is made within the warranty period set forth above, Buyer may return such goods to GAI-Tronics' nearest depot repair facility, freight prepaid, at which time they will be repaired or replaced, at Seller's option, without charge to Buyer. Repair or replacement shall be Buyer's sole and exclusive remedy. The warranty period on any repaired or replacement equipment shall be the greater of the ninety (90) day repair warranty or one (1) year from the date the original equipment was shipped. In no event shall GAI-Tronics warranty obligations with respect to equipment exceed 100% of the total cost of the equipment supplied hereunder. Buyer may also be entitled to the manufacturer's warranty on any third-party goods supplied by GAI-Tronics hereunder. The applicability of any such third-party warranty will be determined by GAI-Tronics.

Services. Any services GAI-Tronics provides hereunder, whether directly or through subcontractors, shall be performed in accordance with the standard of care with which such services are normally provided in the industry. If the services fail to meet the applicable industry standard, GAI-Tronics will re-perform such services at no cost to buyer to correct said deficiency to Company's satisfaction provided any and all issues are identified prior to the demobilization of the Contractor's personnel from the work site. Re-performance of services shall be Buyer's sole and exclusive remedy, and in no event shall GAI-Tronics warranty obligations with respect to services exceed 100% of the total cost of the services provided hereunder.

Warranty Periods. Every claim by Buyer alleging a defect in the goods and/or services provided hereunder shall be deemed waived unless such claim is made in writing within the applicable warranty periods as set forth above. Provided, however, that if the defect complained of is latent and not discoverable within the above warranty periods, every claim arising on account of such latent defect shall be deemed waived unless it is made in writing within a reasonable time after such latent defect is or should have been discovered by Buyer.

Limitations / Exclusions. The warranties herein shall not apply to, and GAI-Tronics shall not be responsible for, any damage to the goods or failure of the services supplied hereunder, to the extent caused by Buyer's neglect, failure to follow operational and maintenance procedures provided with the equipment, or the use of technicians not specifically authorized by GAI-Tronics to maintain or service the equipment. **THE WARRANTIES AND REMEDIES CONTAINED HEREIN ARE IN LIEU OF AND EXCLUDE ALL OTHER WARRANTIES AND REMEDIES, WHETHER EXPRESS OR IMPLIED BY OPERATION OF LAW OR OTHERWISE, INCLUDING ANY WARRANTIES OF MERCHANTABILITY OR FITNESS FOR A PARTICULAR PURPOSE.**

## Return Policy

---

If the equipment requires service, contact your Regional Service Center for a return authorization number (RA#). Equipment should be shipped prepaid to GAI-Tronics with a return authorization number and a purchase order number. If the equipment is under warranty, repairs or a replacement will be made in accordance with the warranty policy set forth above. Please include a written explanation of all defects to assist our technicians in their troubleshooting efforts.

Call 800-492-1212 (inside the USA) or 610-777-1374 (outside the USA) for help identifying the Regional Service Center closest to you.