

For providing pilot wire to ground short indication.

For Low and Medium Voltage Cables Up to 1000 Volts. Developed to comply with MSHA requirements, the tone monitor interrupts power to the mining machine if the ground wire is broken.



- The system ignores the parallel ground path effect. This being negated by means of the ground wire trap in series with the ground wire at the power center.
- For monitoring ground wires of continuous miners, cutting machines, shuttle cars, roof bolters and other mining equipment.
- Detects short circuit between pilot wire and ground wire.
- Simplified system — immune to voltage transients.
- More reliable than impedance type pilot wire systems.
- No interaction on multiple installations.
- Provides capability for remote power shutdown.
- Simplified installations, no phasing required.
- May be installed and tested with no power on the power cable.

Specifications

Mechanical:

Stainless Steel 7.46" H x 2.32"W x 5.62" D

Electrical:

- Power 117 VAC, 50/60 Hz \pm 15% (105V to 135V)
- One plug-in PC board contains all electronics, including the relay
- Frequency 4000 Hz

Ordering Information

- Ground Sentinel GM8000
- Pilot Wire Filter FI2560
- Pilot Wire Choke FI2558
- Ground Wire Trap GM1004

A Pilot Wire System includes a Ground Sentinel, a Pilot Wire Filter, a Pilot Wire Choke, and a Ground Wire Trap.

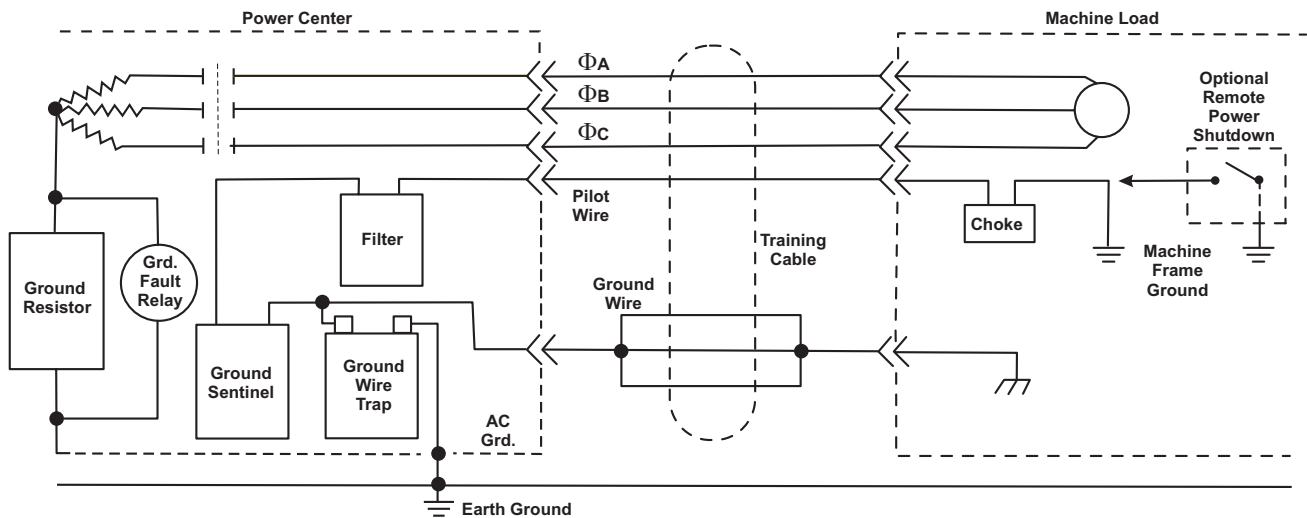

Pub. 070505



GAI-Tronics® USA (Corporate) Toll Free: 1 (800) 492-1212 Tel: (610) 777-1374 Fax: (610) 796-5954 www.gai-tronics.com
 GAI-Tronics® UK Tel: +44 (0)1283 500500 Fax: +44 (0)1283 500400 www.gai-tronics.co.uk
 GAI-Tronics® S.r.l - Italy Tel: +39 02 4588801 Fax: +39 02 93663110 www.gai-tronics.it
 GAI-Tronics® Malaysia Tel: +60-3-8945-4035 / 8945-7348 Fax: +60-3-8945-4675 www.gai-tronics.com
 GAI-Tronics® Austdac - Australia Tel: 011-61-28-851-5000 Fax: 011-61-29-899-2490 www.austdac.com.au

Quality Management System Certified by DNV - ISO 9001:2008

The policy of GAI-Tronics is one of continuous improvement; therefore the company reserves the right to change specifications without notice.